

REV	DESCRIPTION	DRAWN	DATE

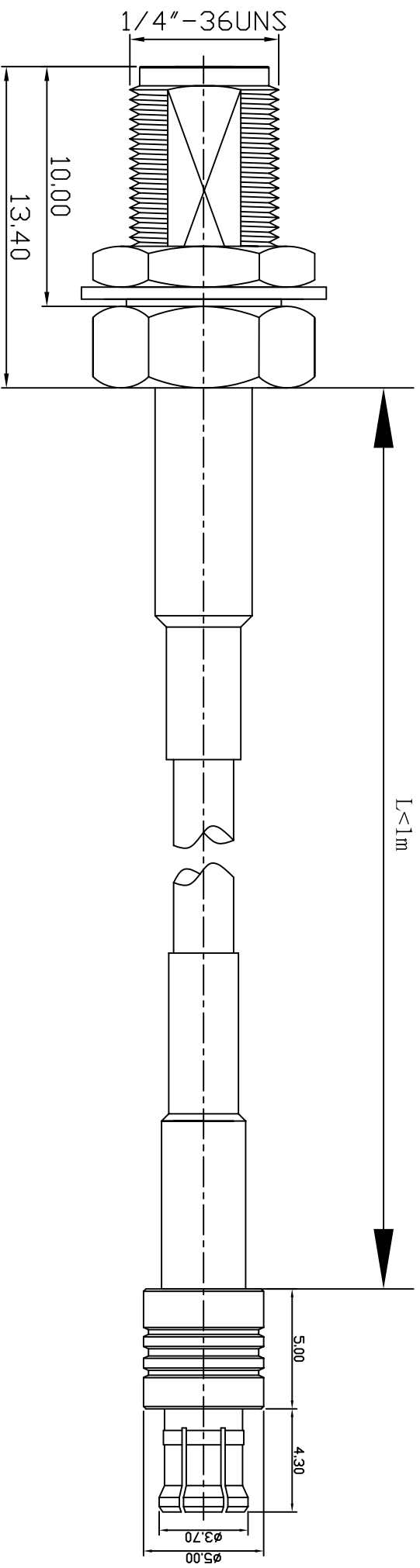

L < 1m

NO	Description	Qty	Material	Finish
3	MCX-901-3-L-TGG	1	BRASS	GOLD
2	RG174/RG316/LLC100	1		
1	SMA-1012-7-L-TGG	1	BRASS	GOLD

UNLESS OTHERWISE SPECIFIED		*MAJOR DIMENSION	
1 REMOVE ALL BURRS		UNLESS OTHERWISE	
2 BREAK ALL CORNERS & EDGES CO.15 MAX.		NOTED TOLERANCES	
3 CHAMFER 1:1 & LAST THREADS 45°		0.5-6 = ±0.2	
4 DIAMETERS ON COMMON CENTERS TO BE CONCENTRIC WITHIN DIMENSIONS ARE		6-30 = ±0.4	
5 AFTER PLATING		30-120 = ±0.6	
		120-315 = ±1.0	
		ANGLES = ±1°	

APPROVED	CHECKED	DRAWN	SCALE	UNIT	MM
		ARNQ	4/1		

<p>華耀科技有限公司 Hua Yao Technologies co.,Ltd</p>	<p>TITLE</p> <p>SMA1012-MCX901</p>
<p>DRAWING NO.</p> <p>9013/174/316/100/10127-1L</p>	<p>REV</p> <p>A</p>

FILE NO.	D:\DWG\SMA1011-MCX901\9013/174/316/100/10127-1L
----------	---