

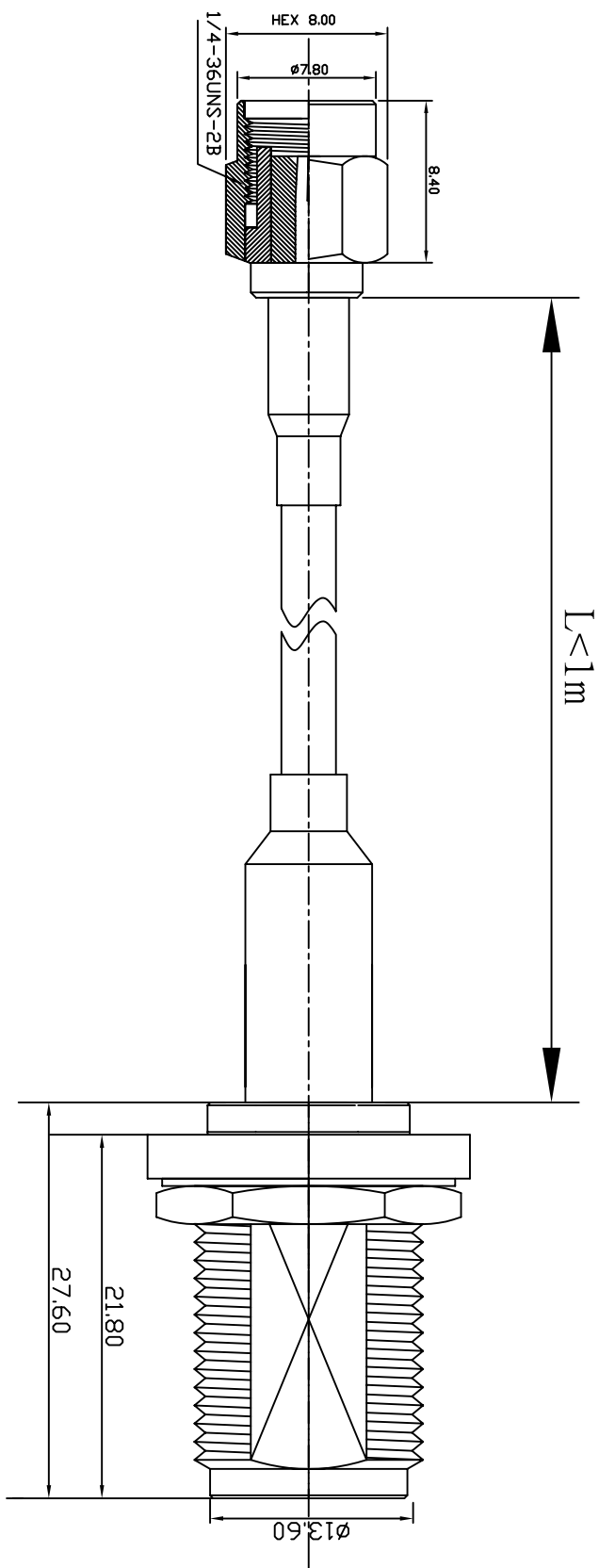

REV	DESCRIPTION	DRAWN	DATE



NO	Description	Qty	Material	Finish
3	N-1159-1-L-TGN	1	BRASS	NICKEL
2	RG174/RG316/LLC100	1		
1	SMA-1001-3-RP-L-TGG	1	BRASS	GOLD

UNLESS OTHERWISE SPECIFIED		*MAJOR DIMENSION		APPROVED	
1 REMOVE ALL BURRS		UNLESS OTHERWISE		CHECKED	
2 BREAK ALL CORNERS & EDGES CO.15 MAX.		NOTED TOLERANCES		DRAWN	
3 CHAMFER 1ST & LAST THREADS 45°		0.5-6=±0.2		PEN	
4 DIAMETERS ON COMMON CENTERS		6-30=±0.4		DRAWN DATE 04/09/29	
5. ALL DIMENSIONS ARE AFTER PLATING.		30-120=±0.6		FILE NDA\DWG\SMA1001-N1159.10013R/174/316/100/11591-1L	
		120-315=±1.0		TITLE	
		ANGLES=±1°		SMA1001-N1159	
				DRAWING NO.	
				10013R/174/316/100/11591-1L	
				REV	
				A	

**華耀科技有限公司**  
 Hua Yao Technologies co.,Ltd