

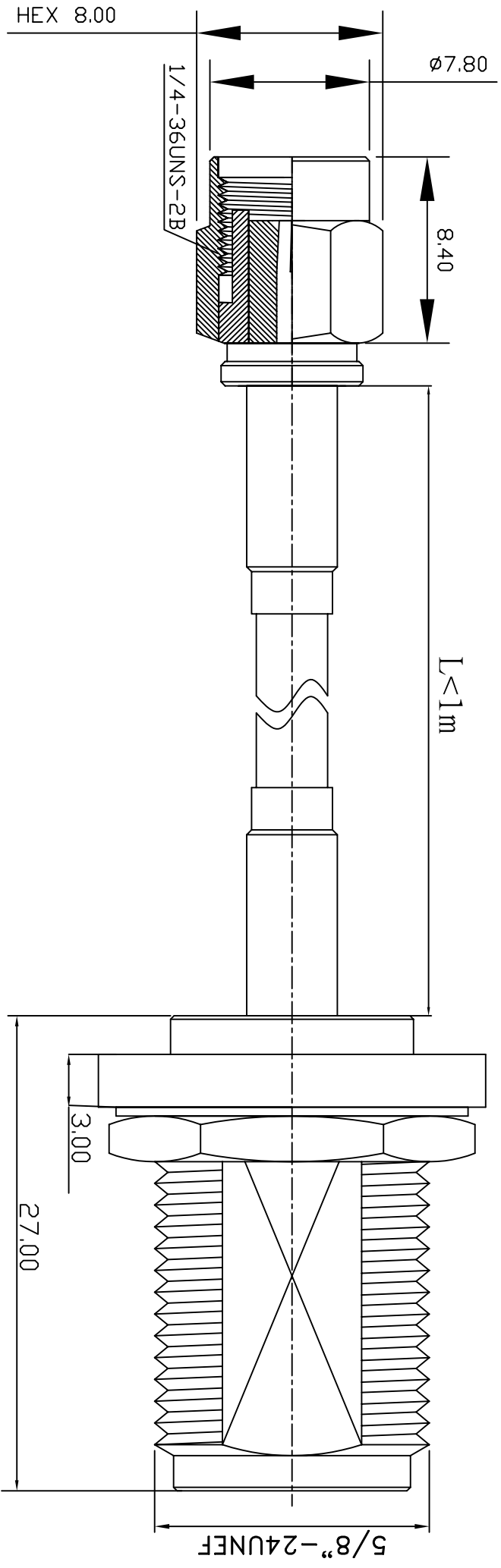

REV	DESCRIPTION	DRAWN	DATE



NO	Description	Qty	Material	Finish
3	N-1112-1-F-TGN	1	BRASS	NICKEL
2	LLC200/RG58	1		
1	SMA-1001-6-F-RP-TGG	1	BRASS	GOLD

1 REMOVE ALL BURRS 2 BREAK ALL CORNERS & EDGES CO.15 MAX. 3 CHAMFER 15° & LAST THREADS 45°. 4 DIAMETERS ON COMMON CENTERS TO BE CONCENTRIC WITH DIMENSIONS ARE AFTER PLATING.		*MAJOR DIMENSION UNLESS OTHERWISE NOTED TOLERANCES 0.5-6=±0.2 6-30=±0.4 30-120=±0.6 120-315=±1.0 ANGLES=±1°		APPROVED CHECKED DRAWN PEN		 <b>華耀科技有限公司</b> <i>Hua Yao Technologies co., Ltd</i>	
SCALE	3/1	UNIT	MM	DRAWN DATE	04/09/29	FILE NO.	D:\DWG\SMA1001-N1112\10016R/200/58/11121-IL
TITLE				DRAWING NO.		REV	
SMA1001-N1112				10016R/200/58/11121-IL		A	