

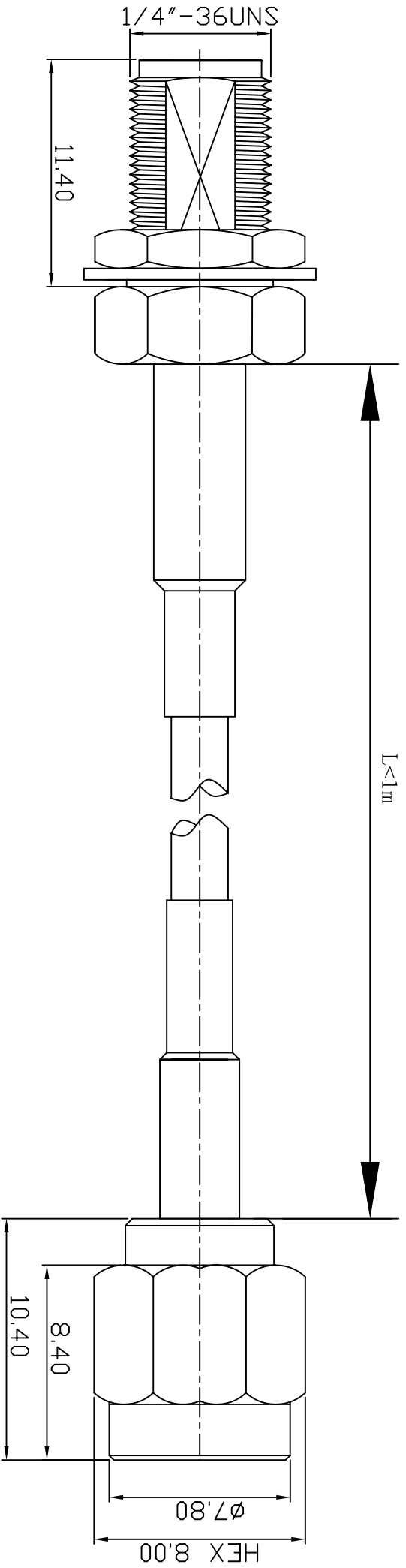

REV	DESCRIPTION	DRAWN	DATE



NO	Description	Qty	Material	Finish
3	SMA-1012-33-F2-TGG	1	BRASS	GOLD
2	LLC200/RG58	1		
1	SMA-1001-5-F-TGG	1	BRASS	GOLD

1 REMOVE ALL BURRS 2 BREAK ALL CORNERS & EDGES CO.15 MAX. 3 CHAMFER 1ST & LAST THREADS 45°. 4 DIAMETERS ON COMMON CENTERS TO BE CONCENTRIC WITH DIMENSIONS ARE AFTER PLATING. UNLESS OTHERWISE SPECIFIED		*MAJOR DIMENSION UNLESS OTHERWISE NOTED TOLERANCES 0.5-6 = ±0.2 6-30 = ±0.4 30-120 = ±0.6 120-315 = ±1.0 ANGLES = ±1°		APPROVED CHECKED DRAWN ARNO		 華耀科技有限公司 <i>Hua Yao Technologies co.,Ltd</i> TITLE SMA1012-SMA1012 DRAWING NO. 121233/200/58/10015-1L REV A	
SCALE	4/1	UNIT	MM	DRAWN DATE	03/06/21	FILE NO.	D:\DWG\SMA1012-SMA1012\121233/200/58/10015-1L