

| REV | DESCRIPTION | DRAWN | DATE |
|-----|-------------|-------|------|
|     |             |       |      |
|     |             |       |      |

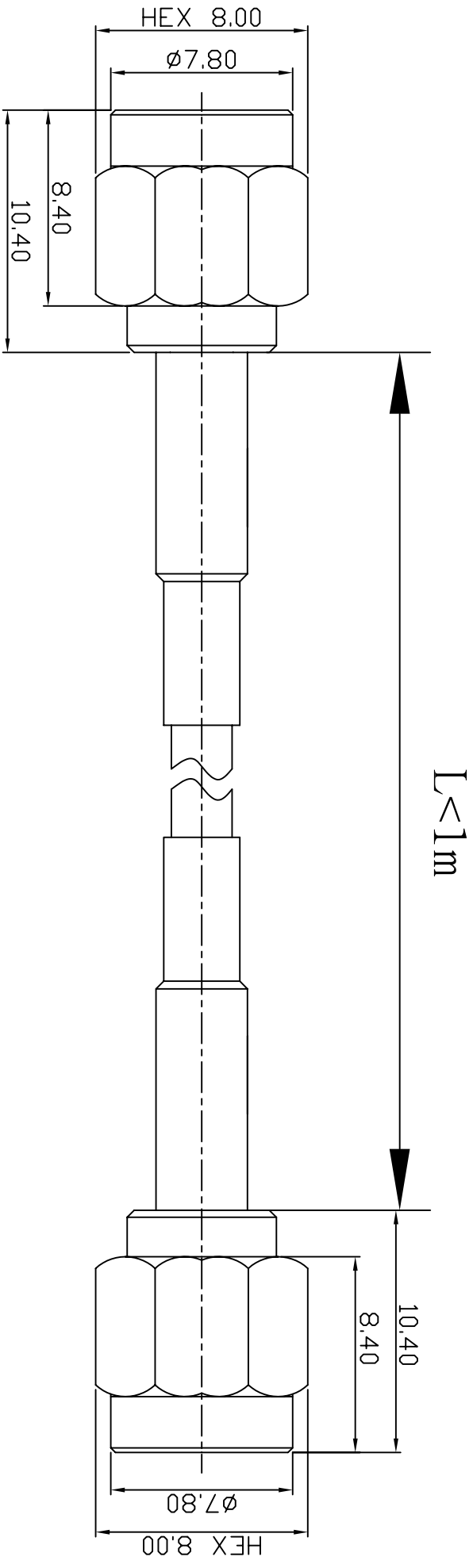

| NO | Description      | Qty | Material | Finish |
|----|------------------|-----|----------|--------|
| 3  | SMA-1001-5-F-TGG | 1   | BRASS    | GOLD   |
| 2  | LLC200/RG58      | 1   |          |        |
| 1  | SMA-1001-5-F-TGG | 1   | BRASS    | GOLD   |

|   |  |                  |  |
|---|--|------------------|--|
| UNLESS OTHERWISE SPECIFIED  |  | *MAJOR DIMENSION |  |
| 1 REMOVE ALL BURRS  |  | UNLESS OTHERWISE |  |
| 2 BREAK ALL CORNERS & EDGES TO 1.5 MAX.   |  | NOTED TOLERANCES |  |
| 3 CHAMFER 1ST & LAST THREADS 45°  |  | 0.5-6 = ±0.2     |  |
| 4 DIAMETERS ON COMMON CENTERS TO BE CONCENTRIC WITH DIMENSIONS ARE AFTER PLATING. |  | 6-30 = ±0.4      |  |
|   |  | 30-120 = ±0.6    |  |
|   |  | 120-315 = ±1.0   |  |
|   |  | ANGLES = ±1°     |  |

|          |         |       |
|----------|---------|-------|
| APPROVED | CHECKED | DRAWN |
|          |         | PEN   |

|       |     |      |    |
|-------|-----|------|----|
| SCALE | 4/1 | UNIT | MM |
|-------|-----|------|----|

|            |          |
|------------|----------|
| DRAWN DATE | 04/06/24 |
|------------|----------|

|  |                          |
|--|--------------------------|
| <br><b>華耀科技有限公司</b><br><i>Hua Yao Technologies co.,Ltd</i> | TITLE<br>SMA1001-SMA1001 |
| DRAWING NO.<br>10015/200/58/10015-1L                       | REV<br>A                 |
| FILE NO. D:\DVG\SMA1001-SMA1001\10015/200/58/10015-1L      |                          |