

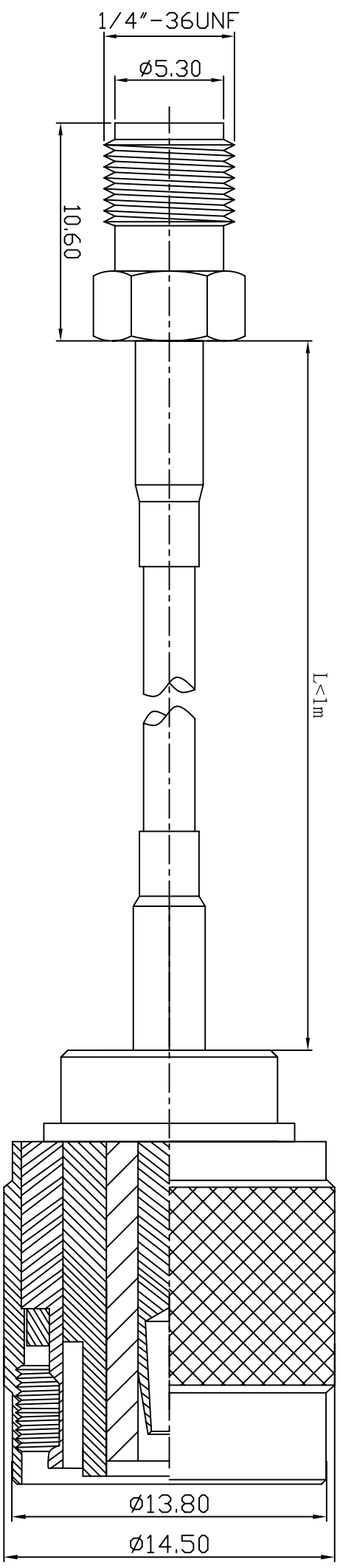

REV	DESCRIPTION	DRAWN	DATE



NO	Description	Qty	Material	Finish
3	TNC-1501-2-L-RP-TGN	1	BRASS	GOLD
2	RG174/RG316/LLC100	1		
1	SMA-1011-1-L-TGC	1	BRASS	GOLD

1 REMOVE ALL BURRS 2 BREAK ALL CORNERS & EDGES CO.15 MAX. 3 CHAMFER 15° & LAST THREADS 45°. 4 DIAMETERS ON COMMON CENTERS TO BE CONCENTRIC WITH DIMENSIONS ARE AFTER PLATING.		*MAJOR DIMENSION UNLESS OTHERWISE NOTED TOLERANCES 0.5-6 = ±0.2 6-30 = ±0.4 30-120 = ±0.6 120-315 = ±1.0 ANGLES = ±1°		APPROVED CHECKED DRAWN ARNO		 <p>華耀科技有限公司 Hua Yao Technologies co.,Ltd</p>
SCALE	4/1	UNIT	MM	DRAWN DATE	03/06/23	

TITLE	SMA1011-TNC1501
REV	A