

REV	DESCRIPTION	DRAWN	DATE

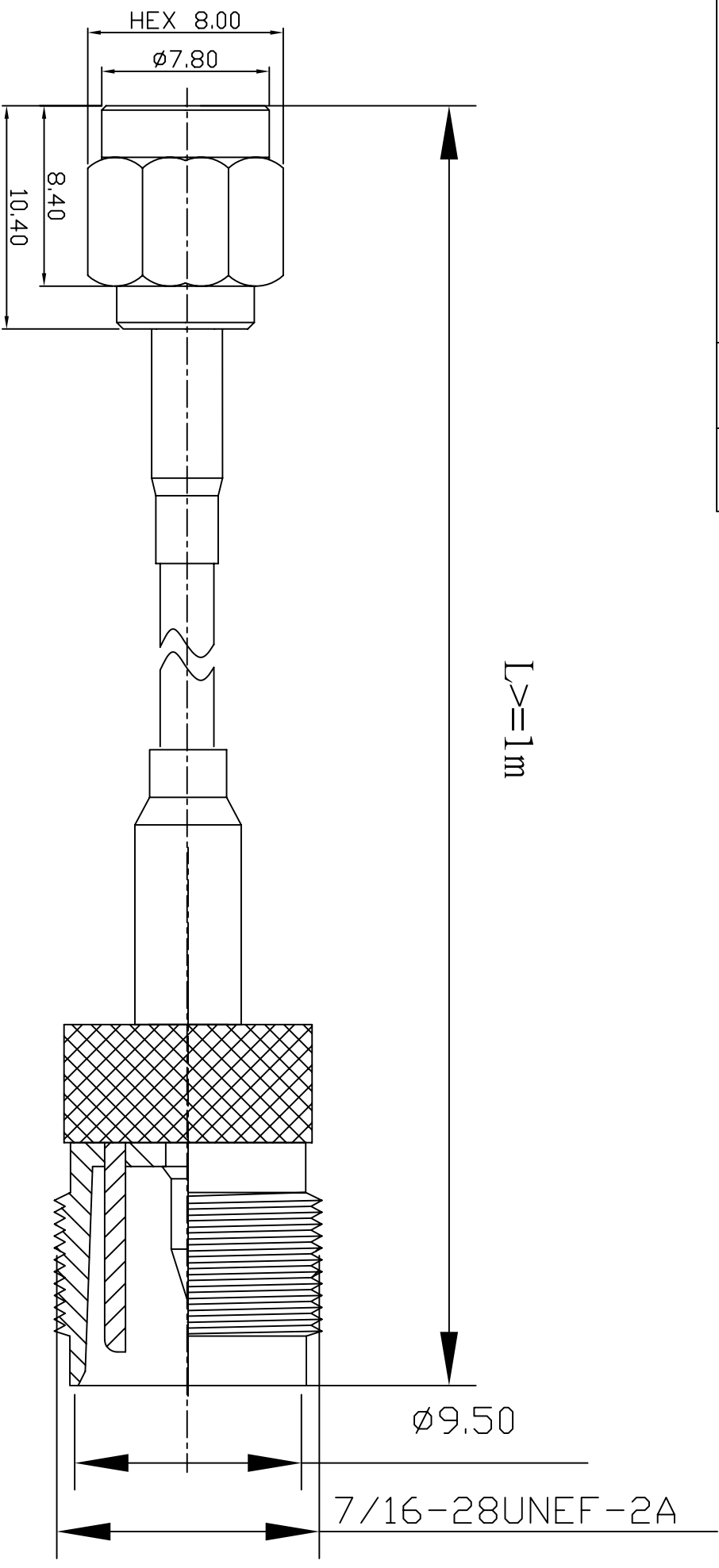

NO	Description	Qty	Material	Finish
3	TNC-1512-4-F-RP-TGN	1	BRASS	NICKEL
2	LLC200/RG58	1		
1	SMA-1001-5-F-TGG	1	BRASS	GOLD

UNLESS OTHERWISE SPECIFIED
 1.REMOVE ALL BURRS
 2.BREAK ALL CORNERS & EDGES CO.15 MAX.
 3.CHAMFER 15° & LAST THREADS 45°.
 4.DIAMETERS ON COMMON CENTERS TO BE CONCENTRIC WITH DIMENSIONS ARE AFTER PLATING.

SCALE	7/2	UNIT	MM

APPROVED	CHECKED	DRAWN	DRAWN DATE
		ARNO	03/06/21

華耀科技有限公司
 Hua Yao Technologies co.,Ltd
 TITLE SMA1001-TNC1512
 DRAWING NO. 10015/200/58/15124R-1L
 FILE NO. D:\DWG\SMA1001-TNC1512\10015/200/58/15124R-1L
 REV A