

REV	DESCRIPTION	DRAWN	DATE

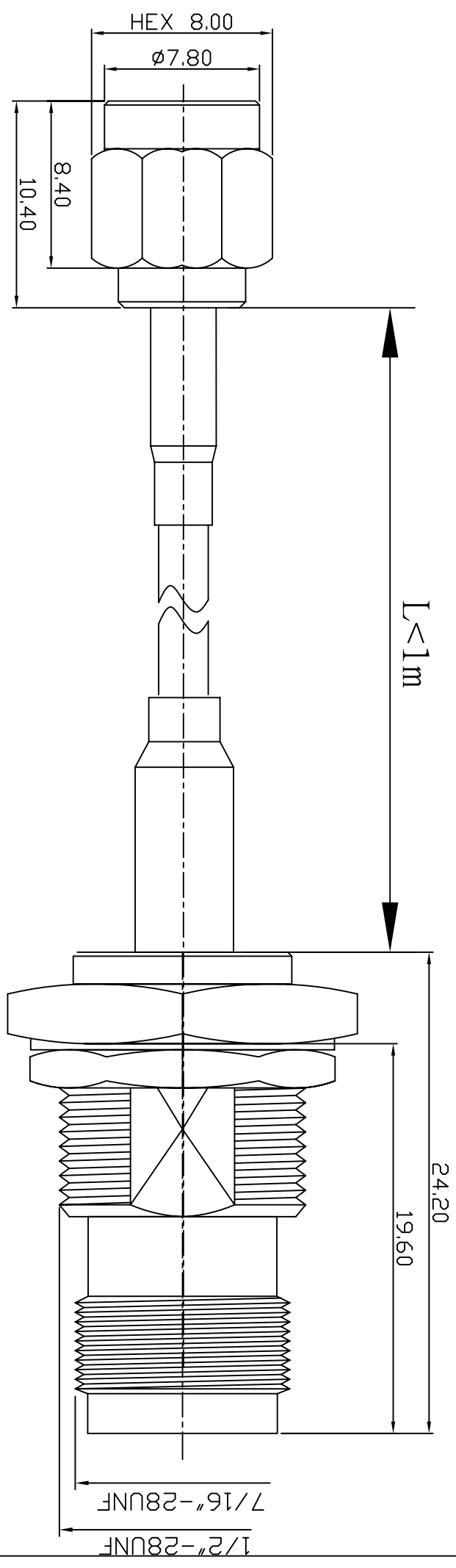

NO	Description	Qty	Material	Finish
3	TNC-1514-11-F-TGN	1	BRASS	NICKEL
2	LLC200/RG58	1		
1	SMA-1001-5-F-TGG	1	BRASS	GOLD

UNLESS OTHERWISE SPECIFIED		*MAJOR DIMENSION	
1 REMOVE ALL BURRS		UNLESS OTHERWISE	
2 BREAK ALL CORNERS & EDGES CO.15 MAX.		NOTED TOLERANCES	
3 CHAMFER 15° & LAST THREADS 45°		0.5-6 = ±0.2	
4 DIAMETERS ON COMMON CENTERS TO BE CONCENTRIC WITHIN DIMENSIONS ARE AFTER PLATING.		6-30 = ±0.4	
		30-120 = ±0.6	
		120-315 = ±1.0	
		ANGLES = ±1°	

APPROVED	CHECKED	TITLE
	ARNO	SMA1001-TNC1511
DRAWN		DRAWING NO.
		10015/200/58/151411-IL
DRAWN DATE 03/06/21	FILE NO.	D:\DWG\SMA1001-TNC1511\10015/200/58/151411-IL
	REV	A

**華耀科技有限公司**  
 Hua Yao Technologies co.,Ltd