

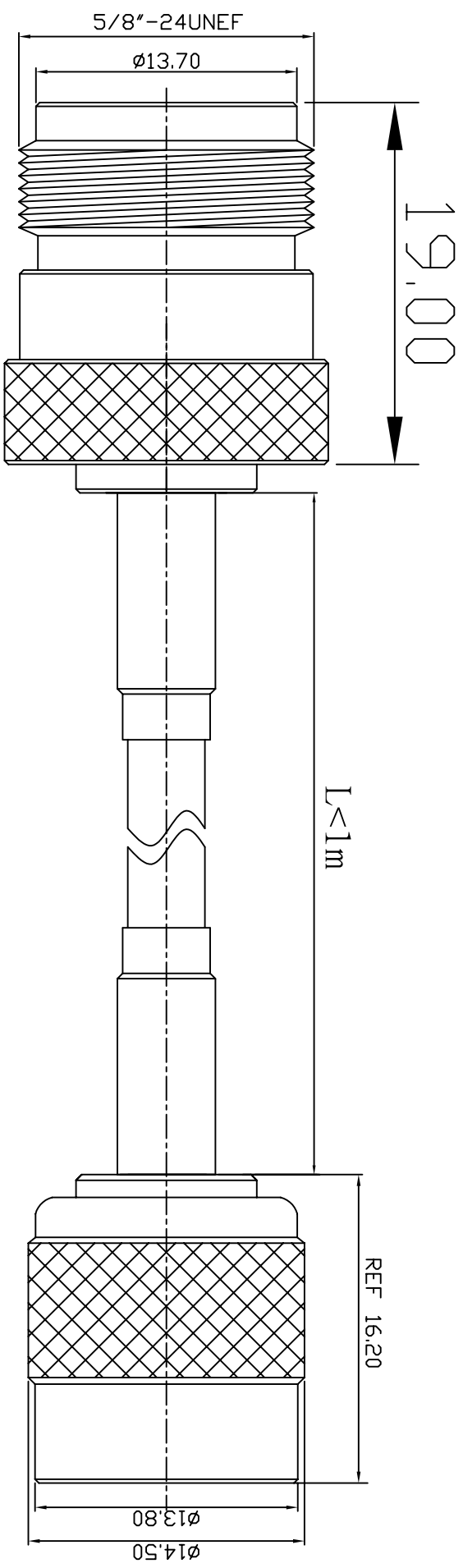

REV	DESCRIPTION	DRAWN	DATE



NO	Description	Qty	Material	Finish
3	TNC-1501-4-F-TGN	1	BRASS	NICKEL
2	LLC200/RG58	1		
1	N-1111-4-F-TGN	1	BRASS	GOLD

UNLESS OTHERWISE SPECIFIED		*MAJOR DIMENSION		APPROVED	
1 REMOVE ALL BURRS		UNLESS OTHERWISE		CHECKED	
2 BREAK ALL CORNERS & EDGES CO.15 MAX.		NOTED TOLERANCES		DRAWN	
3 CHAMFER 1ST & LAST THREADS 45°		0.5-6 = ± 0.2		PEN	
4 DIAMETERS ON COMMON CENTERS TO BE CONCENTRIC WITH DIMENSIONS ARE AFTER PLATING.		6-30 = ± 0.4		DRAWN DATE 04/09/29	
		30-120 = ± 0.6		FILE NO. D:\DWG\11111-TNC1501\11114\200\58\15014-1L	
		120-315 = ± 1.0		TITLE	
		ANGLES = $\pm 1^\circ$		DRAWING NO. N1111-TNC1501	
				REV A	

華耀科技有限公司
 Hua Yao Technologies co.,Ltd