

REV	DESCRIPTION	DRAWN	DATE

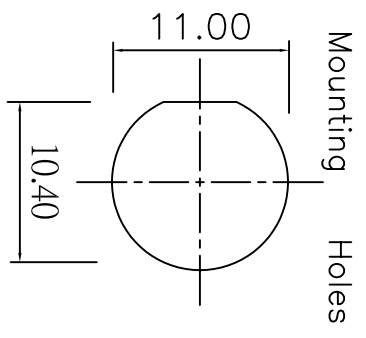
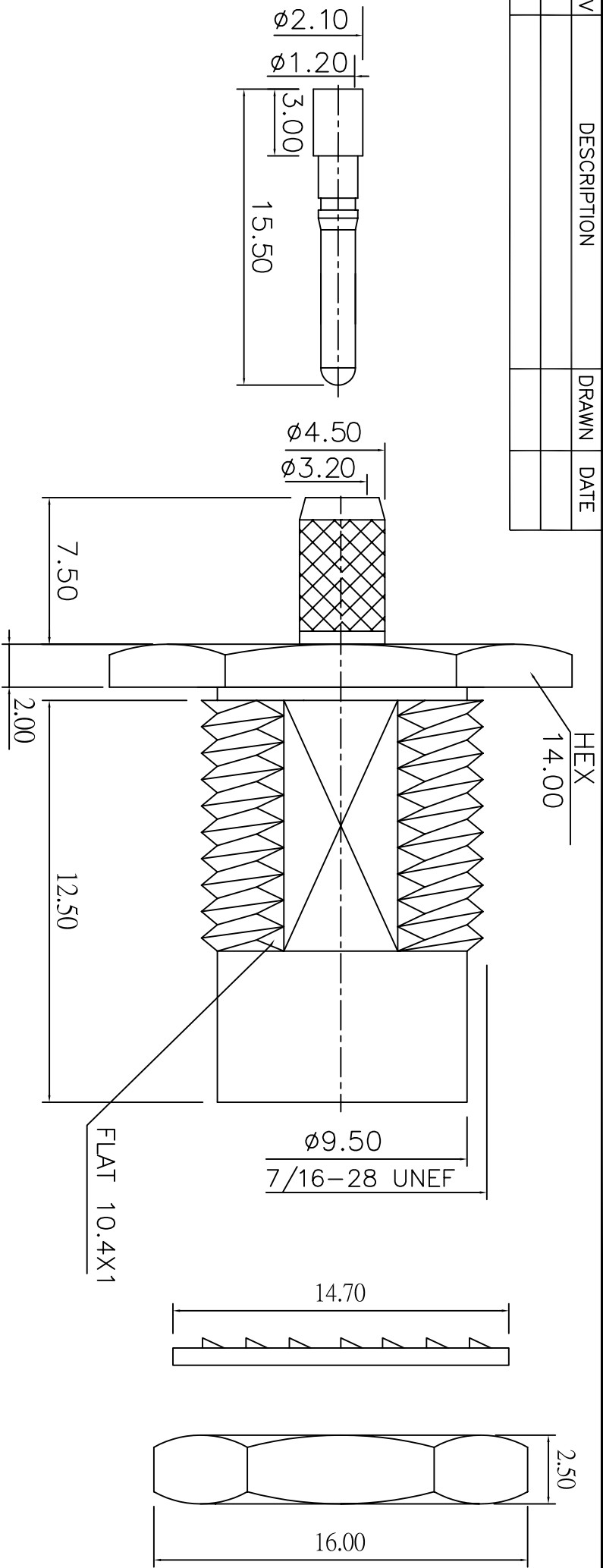

NO	Description	Qty	Material	Finish
6	Support	1	Delrin	White
5	Nut	1	Brass	Nickel
4	Washer	1	Steel	Nickel
3	Insulator	1	Delrin	None
2	Contact	1	Brass	Gold
1	Body	1	Brass	Nickel

UNLESS OTHERWISE SPECIFIED
 1.REMOVE ALL BURRS
 2.BREAK ALL CORNERS & EDGES CO.1.5 MAX.
 3.CHAMFER 15° & LAST THREADS 45°.
 4.DIAMETERS ON COMMON CENTERS.
 TO BE CONCENTRIC WITH DIMENSIONS ARE AFTER PLATING.

* MAJOR DIMENSION UNLESS OTHERWISE NOTED TOLERANCES
 0.5-6=±0.2
 6-30=±0.4
 30-120=±0.6
 120-315=±1.0
 ANGLES=±1°

APPROVED
 CHECKED
 DRAWN
 Betty

華耀科技有限公司
 Hua Yao Technologies co.,Ltd
 TITLE: FME MALE BULKHEAD CRIMP 58U
 DRAWING NO.: FME-2025-5-F-DGN
 FILE NO.: D:\DWG\FME MALE BULKHEAD CRIMP 58U\FME-2025-5-F-DGN
 REV: A
 GL