

REV	DESCRIPTION	DRAWN	DATE

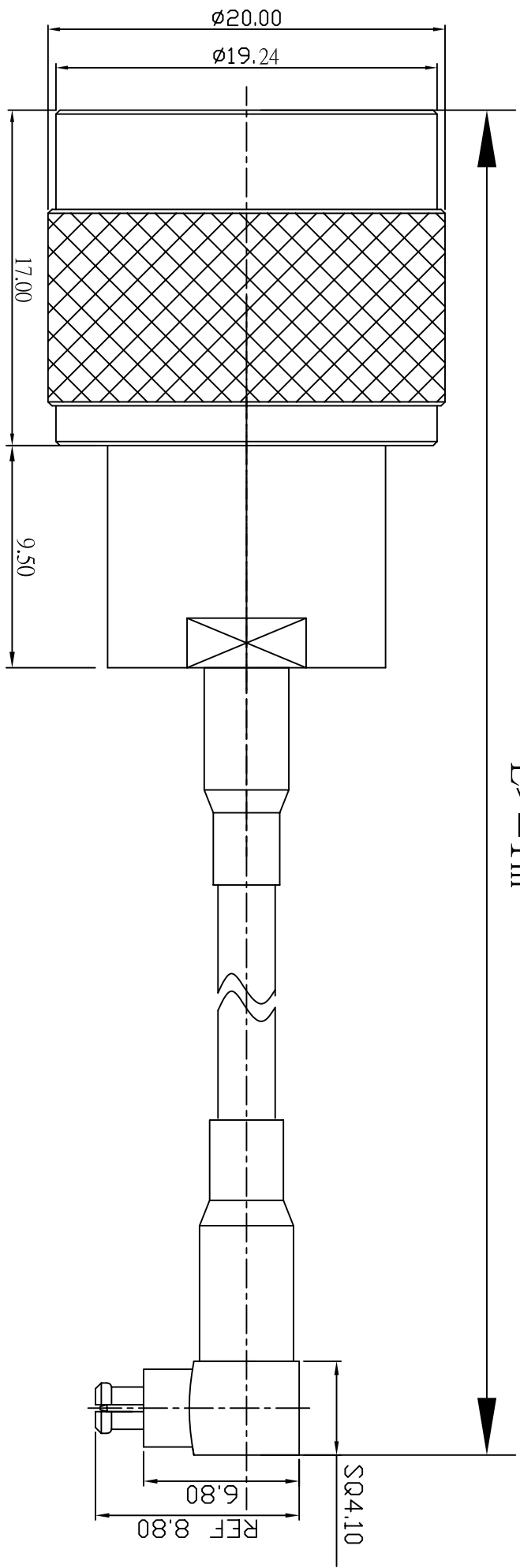

$L \geq 1m$

NO	Description	Qty	Material	Finish
3	MC CARD-2501-3-L-TGN	1	BRASS	GOLD
2	RG174/RG316/LLC100	1		
1	N-1158-2-L-TGN	1	BRASS	NICKEL

UNLESS OTHERWISE SPECIFIED		*MAJOR DIMENSION		APPROVED	
1 REMOVE ALL BURRS		UNLESS OTHERWISE		CHECKED	
2 BREAK ALL CORNERS & EDGES CO.15 MAX.		NOTED TOLERANCES		DRAWN	
3 CHAMFER 1ST & LAST THREADS 45°		0.5-6=±0.2		PEN	
4 DIAMETERS ON COMMON CENTERS TO BE CONCENTRIC WITH DIMENSIONS ARE		6-30=±0.4		DRAWN DATE 05/05/04	
5 AFTER PLATING.		30-120=±0.6		FILE NO. D:\DWG\1158-MC CARD2501\11582174\316/100/25013-AL	
		120-315=±1.0		TITLE N1158-MC CARD2501	
		ANGLES=±1°		DRAWING NO. 11582/174/316/100/25013-AL	
		SCALE 3/1		REV A	
		UNIT MM			

華耀科技有限公司
 Hua Yao Technologies co.,Ltd