

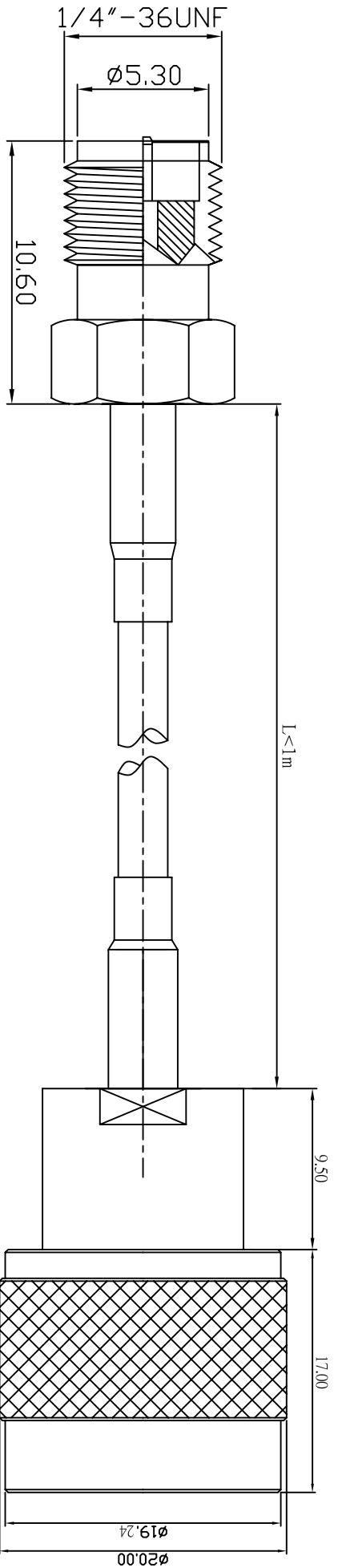

REV	DESCRIPTION	DRAWN	DATE



NO	Description	Qty	Material	Finish
3	N-1158-2-L-TGN	1	BRASS	GOLD
2	RG174/RG316/LLC100	1		
1	SMA-1011-2-RP-L-TGG	1	BRASS	GOLD

UNLESS OTHERWISE SPECIFIED		*MAJOR DIMENSION		APPROVED		 華耀科技有限公司 <i>Hua Yao Technologies co.,Ltd</i>
1.REMOVE ALL BURRS 2.BREAK ALL CORNERS & EDGES CO.1.5 MAX. 3.CHAMFER 1ST & LAST THREADS 45°. 4.DIAMETERS ON COMMON CENTERS TO BE CONCENTRIC WITHIN DIMENSIONS ARE AFTER PLATING.		UNLESS OTHERWISE NOTED TOLERANCES 0.5-6=±0.2 6-30=±0.4 30-120=±0.6 120-315=±1.0 ANGLES=±1°		CHECKED	DRAWN	
SCALE	4/1	UNIT	MM	DRAWN DATE	03/06/23	DRAWING NO.
						11582/174/316/100/10112R-1L
						REV
						A
						FILE NO. D:\DWG\SMA1011-N1158\11582/174/316/100/10112R-1L