

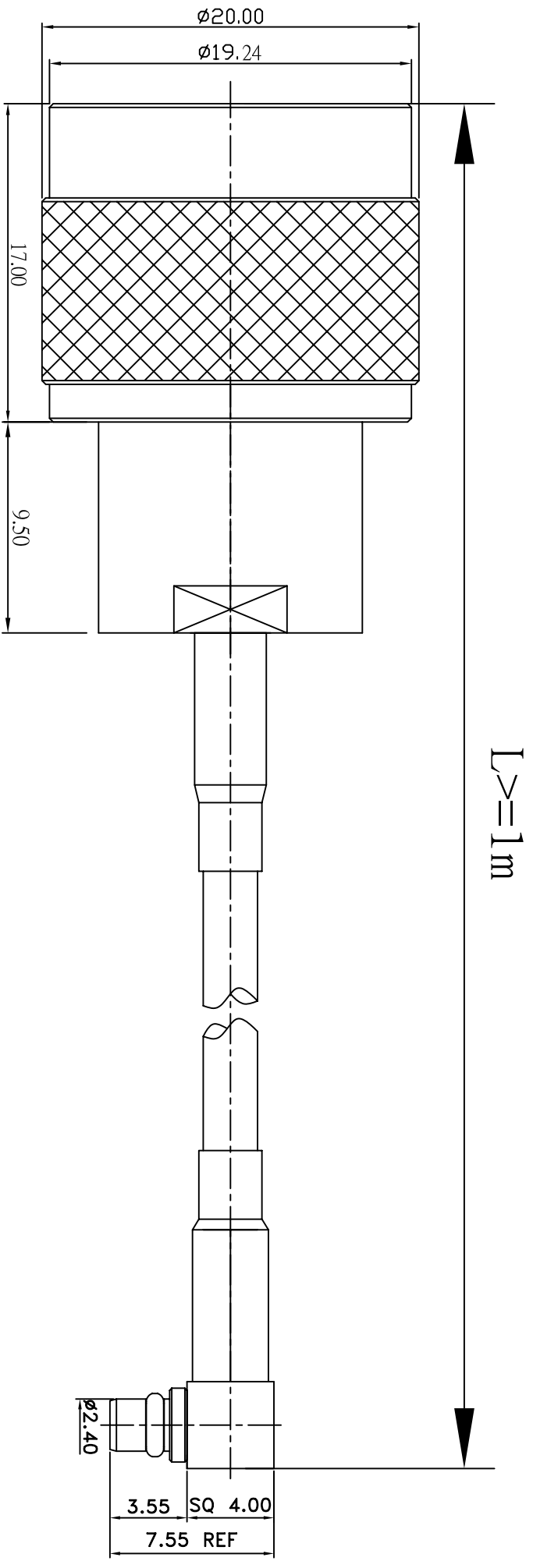

REV	DESCRIPTION	DRAWN	DATE



$L \geq 1m$

NO	Description	Qty	Material	Finish
3	MMCX-802-1-L-TGG	1	BRASS	GOLD
2	RG174/RG316/LLC100	1		
1	N-1158-2-L-TGN	1	BRASS	GOLD

UNLESS OTHERWISE SPECIFIED		*MAJOR DIMENSION		APPROVED	
1. REMOVE ALL BURRS	UNLESS OTHERWISE NOTED	SCALE	UNIT	CHECKED	DRAWN ARNO
2. BREAK ALL CORNERS & EDGES TO 1.5 MAX.	0.5-6 = ±0.2	4/1	MM	DRAWN DATE 03/06/23	
3. CHAMFER 1ST & LAST THREADS 45°	6-30 = ±0.4				
4. DIAMETERS ON COMMON CENTERS	30-120 = ±0.6				
5. ALL DIMENSIONS ARE AFTER PLATING.	120-315 = ±1.0				
	ANGLES = ±1°				

 <p>華耀科技有限公司 Hua Yao Technologies co., Ltd</p>	<p>TITLE N1158-MMCX802</p> <p>DRAWING NO. 8021/174/316/100/11582-AL</p>	<p>FILE NO. D:\DWG\1158-MMCX802\9021/174/316/100/11582-AL</p>
	REV A	