

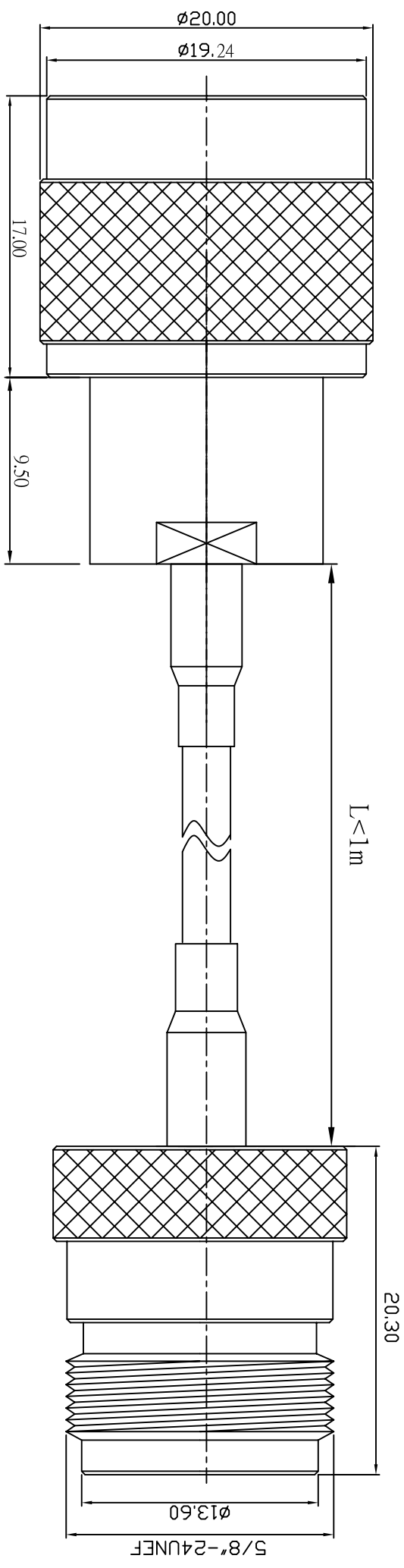

REV	DESCRIPTION	DRAWN	DATE



NO	Description	Qty	Material	Finish
3	N-1111-8-L-TGN	1	BRASS	GOLD
2	RG174/RG316/LLC100	1		
1	N-1158-2-L-TGN	1	BRASS	NICKEL

1 REMOVE ALL BURRS 2 BREAK ALL CORNERS & EDGES CO.15 MAX. 3 CHAMFER 1ST & LAST THREADS 45° 4 DIAMETERS ON COMMON CENTERS TO BE CONCENTRIC WITH DIMENSIONS ARE AFTER PLATING.		*MAJOR DIMENSION UNLESS OTHERWISE NOTED TOLERANCES 0.5-6 = ±0.2 6-30 = ±0.4 30-120 = ±0.6 120-315 = ±1.0 ANGLES = ±1°		APPROVED CHECKED DRAWN PEN		 華耀科技有限公司 <i>Hua Yao Technologies co.,Ltd</i>	
SCALE	3/1	UNIT	MM	DRAWN DATE	05/05/04	FILE NO.	D:\DWG\1158-N1111\11582/174/316/100/1118-1L
				TITLE	N1158-N1111		
				DRAWING NO.	11582/174/316/100/11118-1L		
				REV	A		