

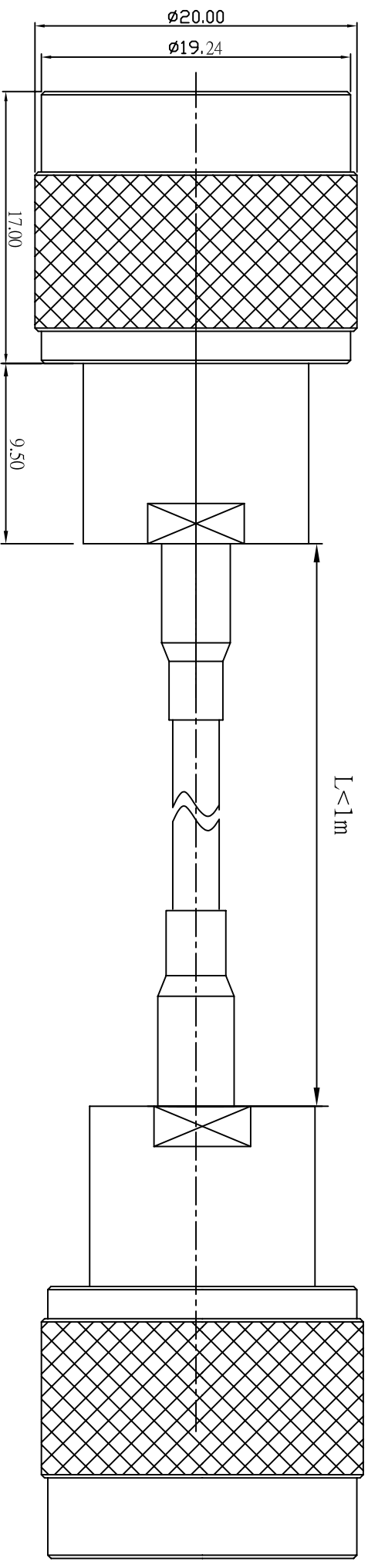

| REV | DESCRIPTION | DRAWN | DATE |
|-----|-------------|-------|------|
| | | | |
| | | | |



| NO | Description | Qty | Material | Finish |
|----|--------------------|-----|----------|--------|
| 3 | N-1158-2-L-TGN | 1 | BRASS | GOLD |
| 2 | RG174/RG316/LLC100 | 1 | | |
| 1 | N-1158-2-L-TGN | 1 | BRASS | NICKEL |

| | | | |
|--|---|-------------------------------------|---|
| 1 REMOVE ALL BURRS 2 BREAK ALL CORNERS & EDGES CO.15 MAX. 3 CHAMFER 1ST & LAST THREADS 45°. 4 DIAMETERS ON COMMON CENTERS TO BE CONCENTRIC WITH DIMENSIONS ARE AFTER PLATING. | *MAJOR DIMENSION UNLESS OTHERWISE NOTED TOLERANCES 0.5-6=±0.2 6-30=±0.4 30-120=±0.6 120-315=±1.0 ANGLES=±1° | APPROVED CHECKED DRAWN PEN |  華耀科技有限公司 <i>Hua Yao Technologies co.,Ltd</i> TITLE N1158-N1158 DRAWING NO. 11582/174/316/100/11582-1L FILE NO. D:\DWG\1158-N1158\11582/174/316/100/11582-1L |
| UNLESS OTHERWISE SPECIFIED | UNLESS OTHERWISE NOTED | SCALE 3/1 UNIT MM | DRAWN DATE 05/05/04 REV A |