

REV	DESCRIPTION	DRAWN	DATE

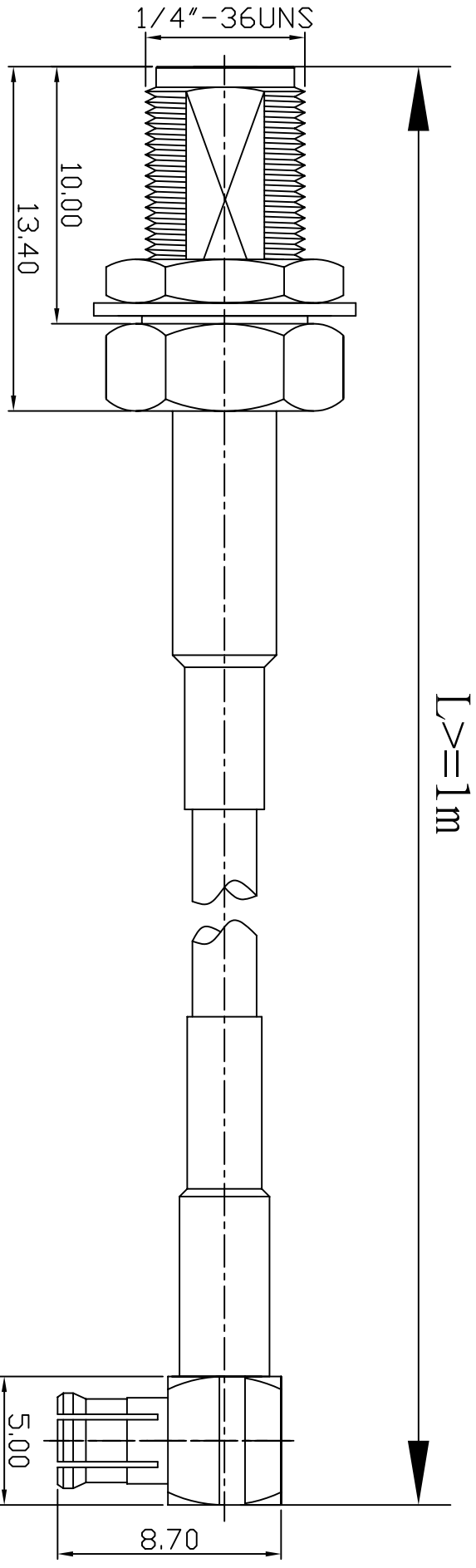
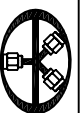

NO	Description	Qty	Material	Finish
3	MCX-902-1-L-TGG	1	BRASS	GOLD
2	RG174/RG316/LLC100	1		
1	SMA-1012-7-L-TGG	1	BRASS	GOLD

1 REMOVE ALL BURRS 2 BREAK ALL CORNERS & EDGES CO.15 MAX. 3 CHAMFER 1ST & LAST THREADS 45° 4 DIAMETERS ON COMMON CENTERS TO BE CONCENTRIC WITHIN DIMENSIONS ARE AFTER PLATING.		*MAJOR DIMENSION UNLESS OTHERWISE NOTED TOLERANCES 0.5-6 = ±0.2 6-30 = ±0.4 30-120 = ±0.6 120-315 = ±1.0 ANGLES = ±1°		APPROVED CHECKED DRAWN ARNO		 華耀科技有限公司 <i>Hua Yao Technologies co.,Ltd</i>	
SCALE	4/1	UNIT	MM	DRAWN DATE	03/06/21	FILE NO.	D:\DWG\SMA1011-MCX902\9021/174/316/100/10127-AL
TITLE				SMA1012-MCX902		DRAWING NO.	
DRAWING NO.				9021/174/316/100/10127-AL		REV	
						A	