

REV	DESCRIPTION	DRAWN	DATE

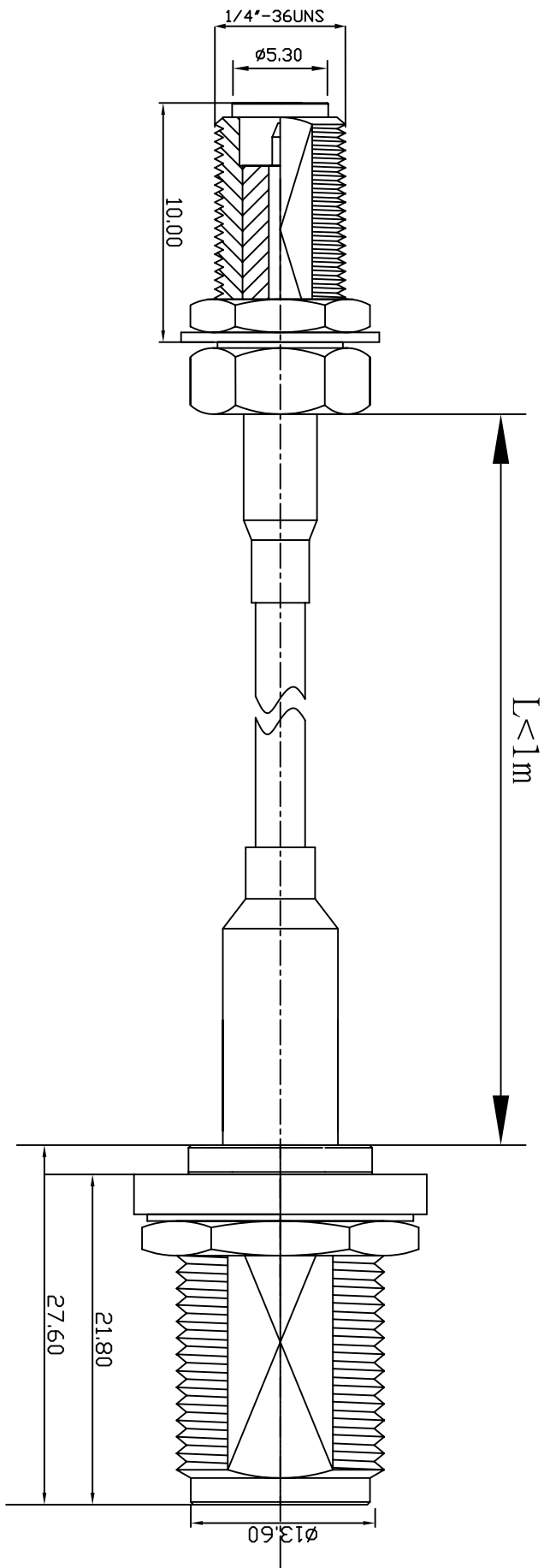

NO	Description	Qty	Material	Finish
3	N-1159-1-L-TGN	1	BRASS	NICKEL
2	RG174/RG316/LLC100	1		
1	SMA-1012-17-L-RP-TGG	1	BRASS	GOLD

UNLESS OTHERWISE SPECIFIED		*MAJOR DIMENSION		APPROVED	
1 REMOVE ALL BURRS		UNLESS OTHERWISE		CHECKED	
2 BREAK ALL CORNERS & EDGES CO.15 MAX.		NOTED TOLERANCES		DRAWN	
3 CHAMFER 1ST & LAST THREADS 45°		0.5-6=±0.2		PEN	
4 DIAMETERS ON COMMON CENTERS TO BE CONCENTRIC WITH DIMENSIONS ARE AFTER PLATING.		6-30=±0.4		DRAWN DATE 04/09/29	
		30-120=±0.6		FILE NO.\DWG\SMA1012-N1159\101217R\174\316\100\11591-IL	
		120-315=±1.0		TITLE	
		ANGLES=±1°		SMA1012-N1159	
				DRAWING NO.	
				101217R/174/316/100/11591-IL	
				REV	
				A	

**華耀科技有限公司**  
 Hua Yao Technologies co.,Ltd