

REV	DESCRIPTION	DRAWN	DATE

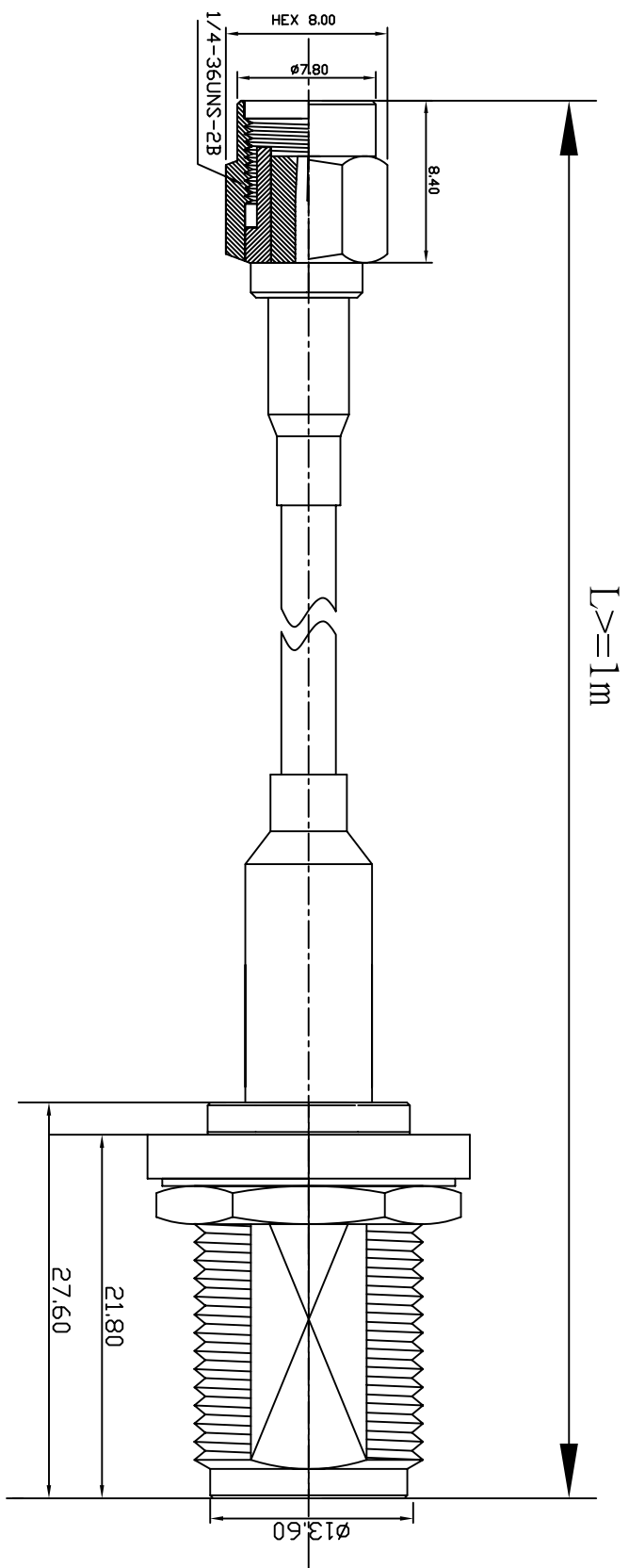

L >= 1 m

NO	Description	Qty	Material	Finish
3	N-1159-1-L-TGN	1	BRASS	NICKEL
2	RG174/RG316/LC100	1		
1	SMA-1001-3-RP-L-TGG	1	BRASS	GOLD

UNLESS OTHERWISE SPECIFIED		*MAJOR DIMENSION		APPROVED	
1 REMOVE ALL BURRS 2 BREAK ALL CORNERS & EDGES CO.15 MAX. 3 CHAMFER 1ST & LAST THREADS 45°. 4 DIAMETERS ON COMMON CENTERS TO BE CONCENTRIC WITHIN DIMENSIONS ARE AFTER PLATING.		UNLESS OTHERWISE NOTED TOLERANCES 0.5-6 = ±0.2 6-30 = ±0.4 30-120 = ±0.6 120-315 = ±1.0 ANGLES = ±1°		CHECKED DRAWN PEN	
SCALE 3/1 UNIT MM		DRAWN DATE 04/09/29		TITLE SMA1001-N1159 DRAWING NO. 10013R/174/316/100/11591-AL	
FILE NDN\DWG\SMA1001-N1159\10013R\174\316\100\11591-AL		REV A		華耀科技有限公司 Hua Yao Technologies co.,Ltd	