

REV	DESCRIPTION	DRAWN	DATE

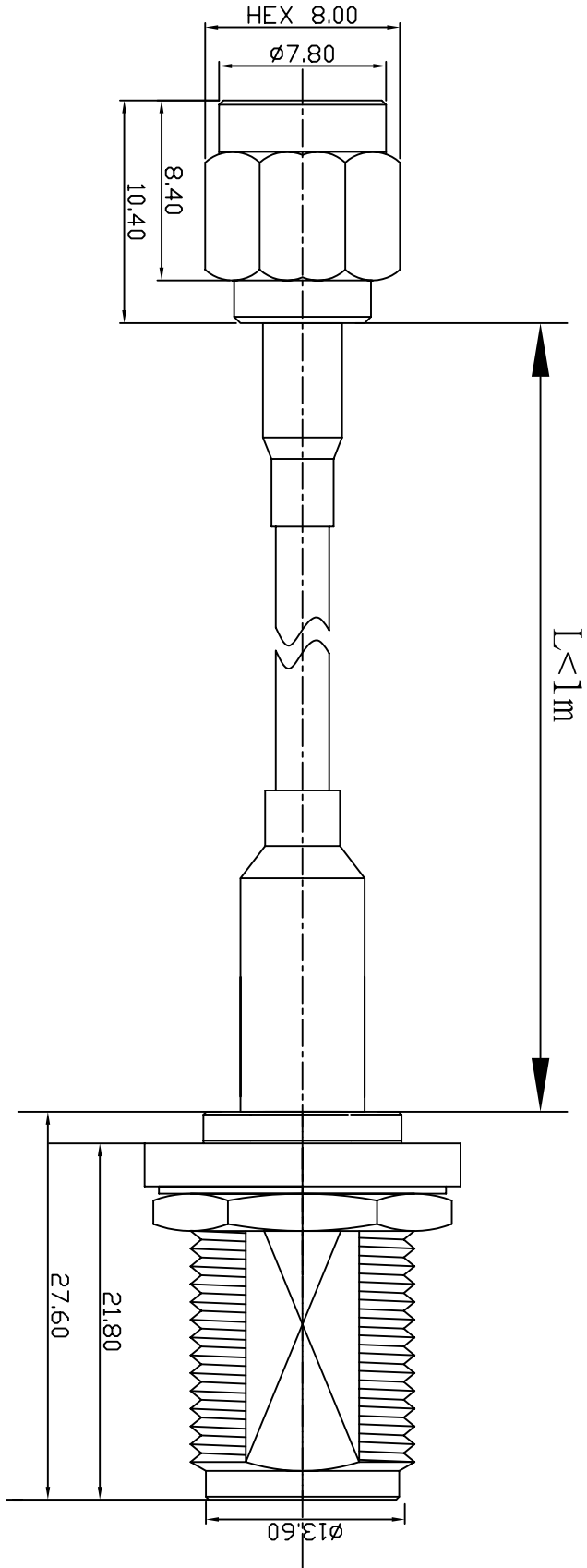

NO	Description	Qty	Material	Finish
3	N-1159-1-L-TGN	1	BRASS	NICKEL
2	RG174/RG316/LLC100	1		
1	SMA-1001-4-L-TGG	1	BRASS	GOLD

UNLESS OTHERWISE SPECIFIED
 1.REMOVE ALL BURRS
 2.BREAK ALL CORNERS & EDGES CO.15 MAX.
 3.CHAMFER 1ST & LAST THREADS 45°.
 4.DIAMETERS ON COMMON CENTERS TO BE CONCENTRIC WITH DIMENSIONS ARE AFTER PLATING.

*MAJOR DIMENSION
 UNLESS OTHERWISE NOTED TOLERANCES
 0.5-6=±0.2
 6-30=±0.4
 30-120=±0.6
 120-315=±1.0
 ANGLES=±1°

APPROVED	CHECKED
DRAWN	PEN
DRAWN DATE 04/09/29	

華耀科技有限公司
Hua Yao Technologies co.,Ltd
 TITLE SMA1001-N1159
 DRAWING NO. 10014/174/316/100/11591-1L
 FILE NDD\DWG\SMA1001-N1159\10014/174/316/100/11591-1L
 REV A