

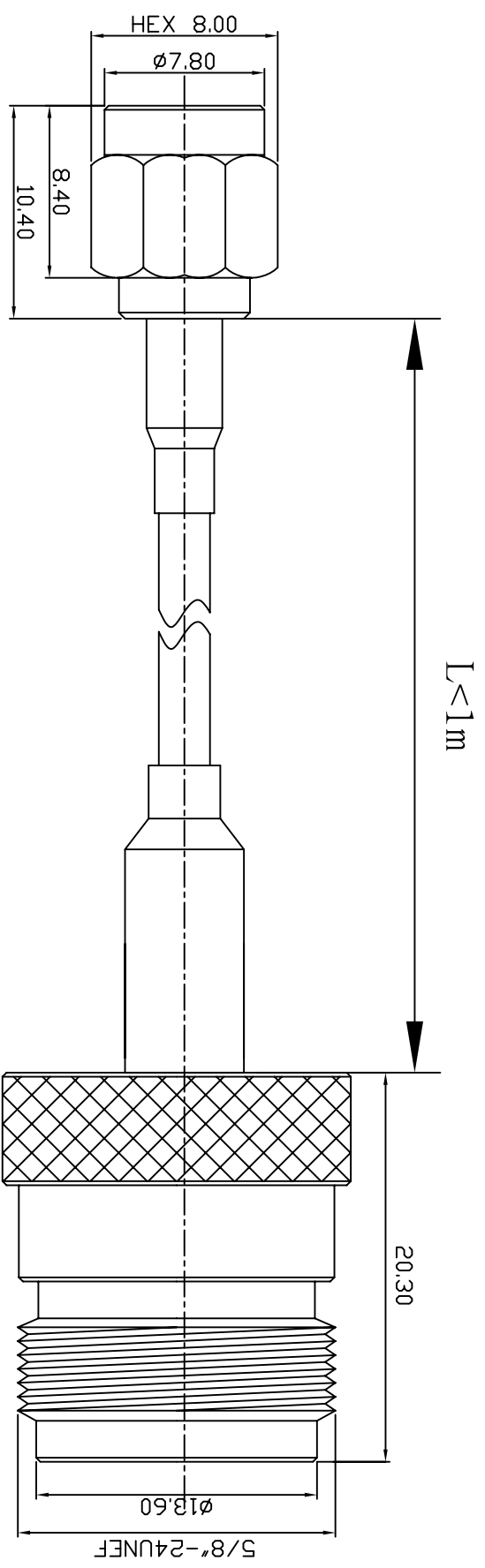

REV	DESCRIPTION	DRAWN	DATE



NO	Description	Qty	Material	Finish
3	N-1111-8-L-TGN	1	BRASS	NICKEL
2	Rg174/Rg316/LC100	1		
1	SMA-1001-4-L-TGG	1	BRASS	GOLD

1 REMOVE ALL BURRS 2 BREAK ALL CORNERS & EDGES CO.15 MAX. 3 CHAMFER 1ST & LAST THREADS 45° 4 DIAMETERS ON COMMON CENTERS TO BE CONCENTRIC WITH DIMENSIONS ARE AFTER PLATING. 5. AFTER PLATING.		*MAJOR DIMENSION UNLESS OTHERWISE NOTED TOLERANCES 0.5-6=±0.2 6-30=±0.4 30-120=±0.6 120-315=±1.0 ANGLES=±1°		APPROVED CHECKED DRAWN PEN		 華耀科技有限公司 <i>Hua Yao Technologies co.,Ltd</i> TITLE SMA1001-N1111 DRAWING NO. 10014/174/316/100/11118-1L REV A	
SCALE	3/1	UNIT	MM	DRAWN DATE	04/09/29	FILE NO.	D:\DWG\SMA1001-N1111\10014/174/316/100/11118-1L