

REV	DESCRIPTION	DRAWN	DATE

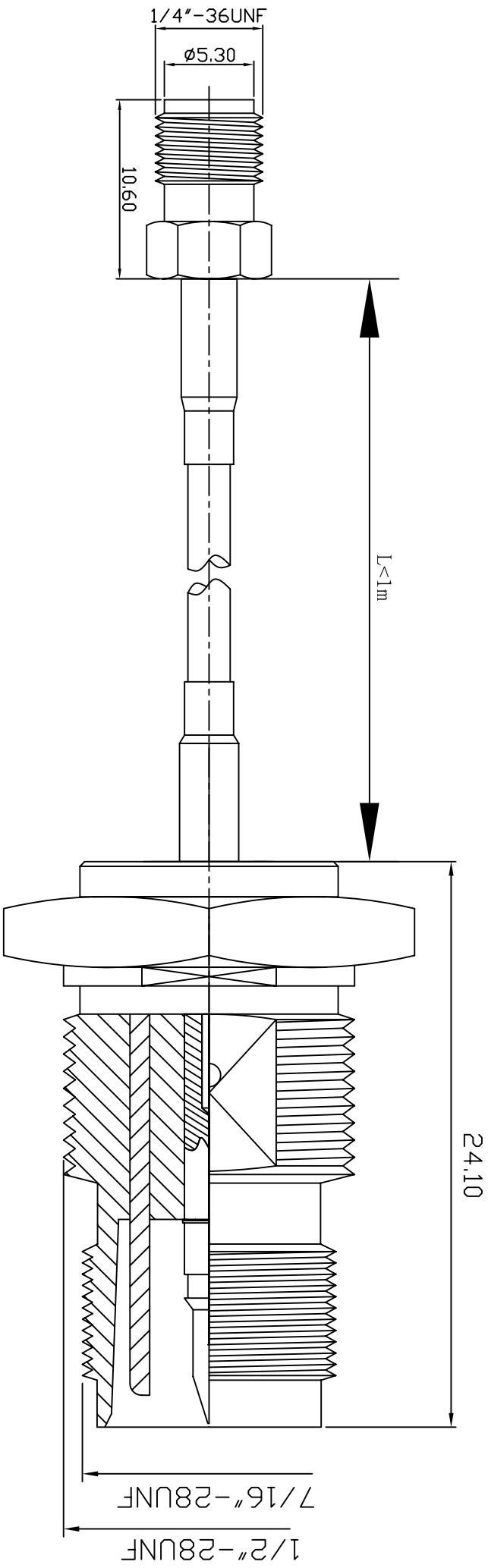

NO	Description	Qty	Material	Finish
3	TNC-1514-12-L-RP-TGN	1	BRASS	GOLD
2	RG174/RG316/LLC100	1		
1	SMA-1011-1-L-TGC	1	BRASS	GOLD

UNLESS OTHERWISE SPECIFIED  
 1 REMOVE ALL BURRS  
 2 BREAK ALL CORNERS & EDGES CO.15 MAX.  
 3 CHAMFER 15° & LAST THREADS 45°.  
 4 DIAMETERS ON COMMON CENTERS TO BE CONCENTRIC WITH DIMENSIONS ARE AFTER PLATING.

\*MAJOR DIMENSION  
 UNLESS OTHERWISE NOTED TOLERANCES  
 0.5-6 = ±0.2  
 6-30 = ±0.4  
 30-120 = ±0.6  
 120-315 = ±1.0  
 ANGLES = ±1°

APPROVED	CHECKED
DRAWN	
ARNO	

**華耀科技有限公司**  
**Hua Yao Technologies co.,Ltd**  
 TITLE SMA1011-TNC1514  
 DRAWING NO. 15142/174/316/100/10111-IL  
 FILE NO. D:\DWG\SMA1011-TNC1514\15142/174/316/100/10111-IL

REV	A