

REV	DESCRIPTION	DRAWN	DATE

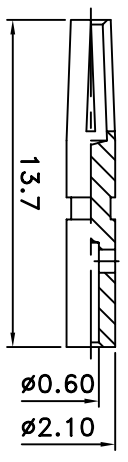
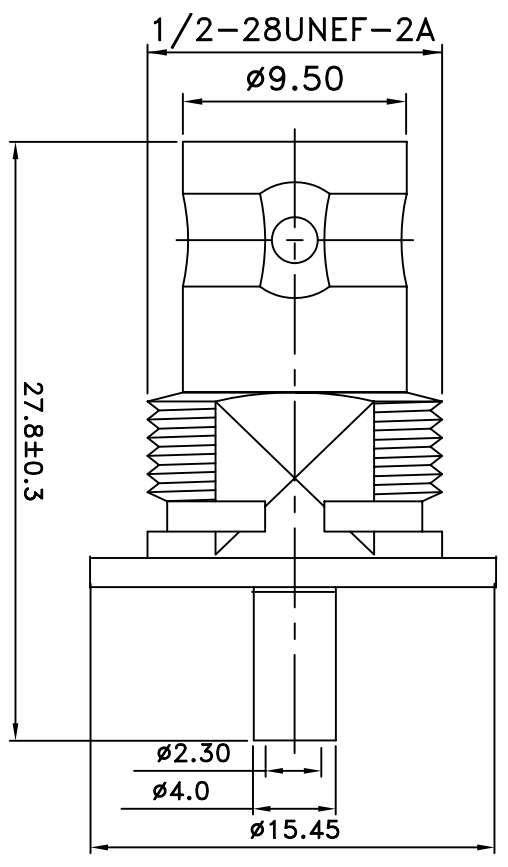
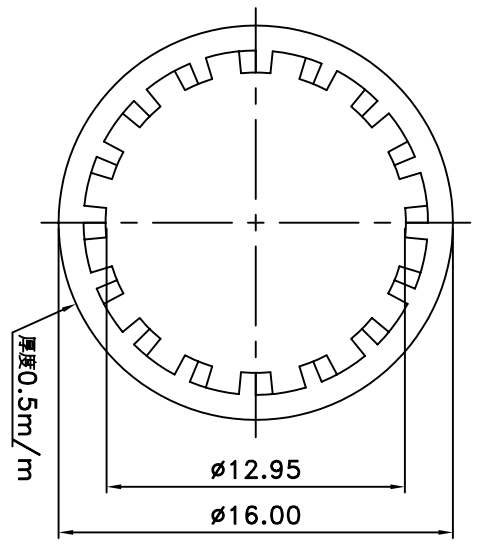
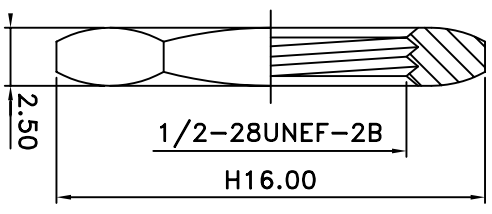

NO	Description	Qty	Material	Finish
7	Nut(N-001)	1	Brass	Nickel
6	Washer(W-002)	1	Iron	Nickel
5	Ferrule(F-023)	1	Brass	Nickel
4	Dielectric	1	Teflon	None
3	Pin(C-02012)	1	Phosphor	Gold
2	Body(B-02008)	1	Brass	Nickel
1	Body(B-02015)	1	Brass	Nickel

UNLESS OTHERWISE SPECIFIED
 1.REMOVE ALL BURRS
 2.BREAK ALL CORNERS & EDGES CO.1.5 MAX.
 3.CHAMFER 15° & LAST THREADS 45°.
 4.DIAMETERS ON COMMON CENTERS.
 5.ALL DIMENSIONS ARE WITHIN DIMENSIONS ARE AFTER PLATING.

* MAJOR DIMENSION UNLESS OTHERWISE NOTED. TOLERANCES
 0.5-6=±0.2
 6-30=±0.4
 30-120=±0.6
 120-315=±1.0
 ANGLES=±1°

APPROVED	CHECKED	DRAWN	SCALE	UNIT	MM	DRAWN DATE
		BON	3/1	MM		05/03/02

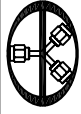
華耀科技有限公司
Hua Yao Technologies co.,Ltd

TITLE: BNC FEMALE BULKHEAD CRIMP 500HM
 DRAWING NO: BNC-1314-1-M-TGN
 REV: A
 FILE NO. D:\DWG\COMPOSE\BNC\BNC-1314-L-TGN