

NOTE:

CENTER PIN GOLD PLATING 3μ THICK OVER NICKEL PLATING
 70μ THICK OVER NICKEL STRIKE
 BODY NICKEL PLATING 70μ THICK OVER NICKEL STRIKE
 BRASS AND PTFE PER SGS
 FINISH PLATING THICKNESS IN MICRO-INCHES
 COPPER PARTS AUTOMATIC CNC MANUFACTURING

Prohibit re-circulating



華耀科技有限公司
Hwa Yao Technologies co.,Ltd

TITLE
 N MALE CRIMP
 DRAWING NO.
 N-1101

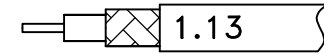
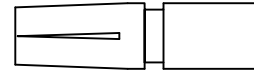
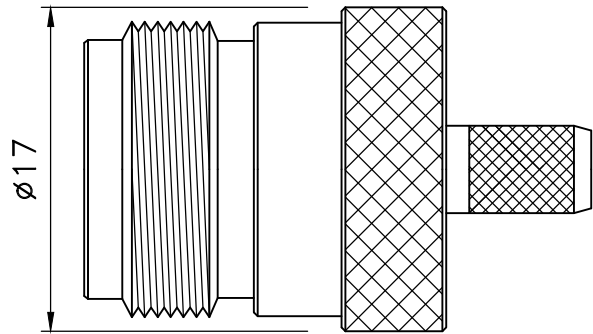

NOTE:

CENTER PIN GOLD PLATING 3μ THICK OVER NICKEL PLATING
 70μ THICK OVER NICKEL STRIKE
 BODY NICKEL PLATING 70μ THICK OVER NICKEL STRIKE
 BRASS AND PTFE PER SGS
 FINISH PLATING THICKNESS IN MICRO-INCHES
 COPPER PARTS AUTOMATIC CNC MANUFACTURING

Prohibit re-circulating



華耀科技有限公司
 Hwa Yao Technologies co.,Ltd

TITLE
 N FEMALE CRIMP

DRAWING NO.
 N-1111

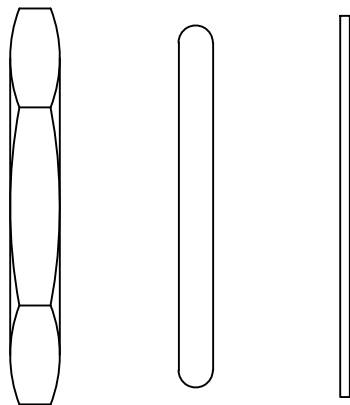
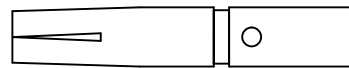
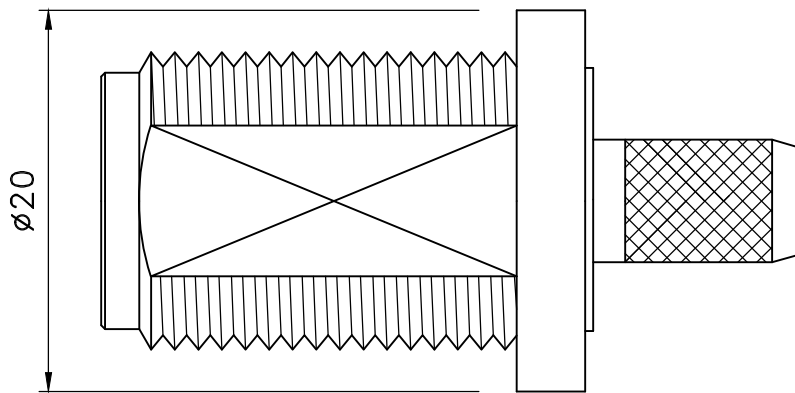

NOTE:

CENTER PIN GOLD PLATING 3 μ THICK OVER NICKEL PLATING
 70 μ THICK OVER NICKEL STRIKE
 BODY NICKEL PLATING 70 μ THICK OVER NICKEL STRIKE
 BRASS AND PTFE PER SGS
 FINISH PLATING THICKNESS IN MICRO-INCHES
 COPPER PARTS AUTOMATIC CNC MANUFACTURING

Prohibit re-circulating



華耀科技有限公司
 Hwa Yao Technologies co.,Ltd

TITLE
 N FEMALE BULKHEAD CRIMP
 DRAWING NO.
 N-1112

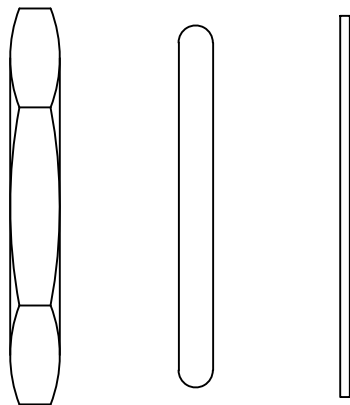
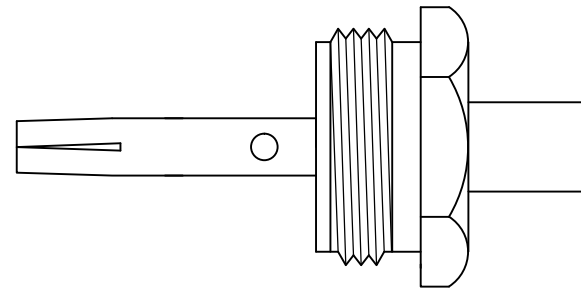
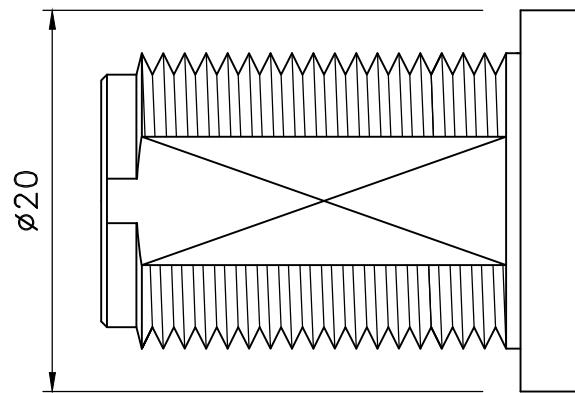

NOTE:

CENTER PIN GOLD PLATING 3 μ THICK OVER NICKEL PLATING
 70 μ THICK OVER NICKEL STRIKE
 BODY NICKEL PLATING 70 μ THICK OVER NICKEL STRIKE
 BRASS AND PTFE PER SGS
 FINISH PLATING THICKNESS IN MICRO-INCHES
 COPPER PARTS AUTOMATIC CNC MANUFACTURING

Prohibit re-circulating



華耀科技有限公司
 Hwa Yao Technologies co.,Ltd

TITLE	N FEMALE BULKHEAD SOLDER
DRAWING NO.	N-1112

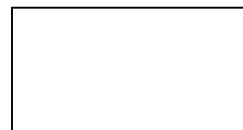
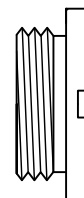
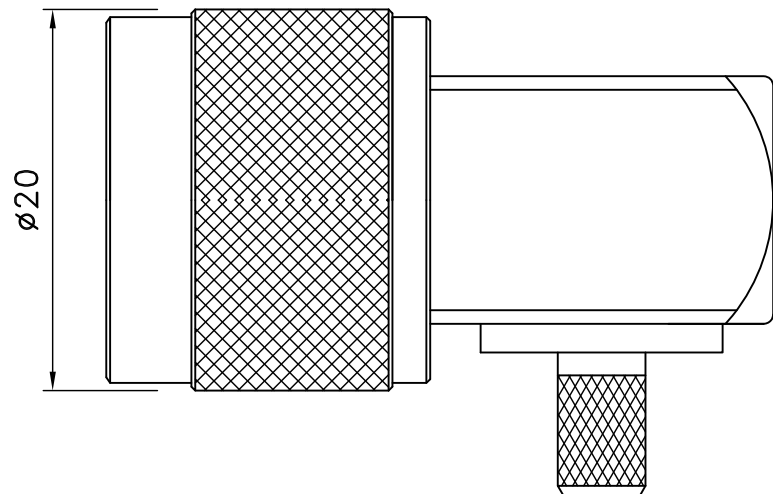

NOTE:

CENTER PIN GOLD PLATING 3μ THICK OVER NICKEL PLATING
 70μ THICK OVER NICKEL STRIKE
 BODY NICKEL PLATING 70μ THICK OVER NICKEL STRIKE
 BRASS AND PTFE PER SGS
 FINISH PLATING THICKNESS IN MICRO-INCHES
 COPPER PARTS AUTOMATIC CNC MANUFACTURING

Prohibit re-circulating



華耀科技有限公司
 Hwa Yao Technologies co.,Ltd

TITLE
 N MALE RIGHT ANGLE CRIMP
 DRAWING NO.
 N-1103

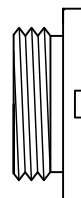
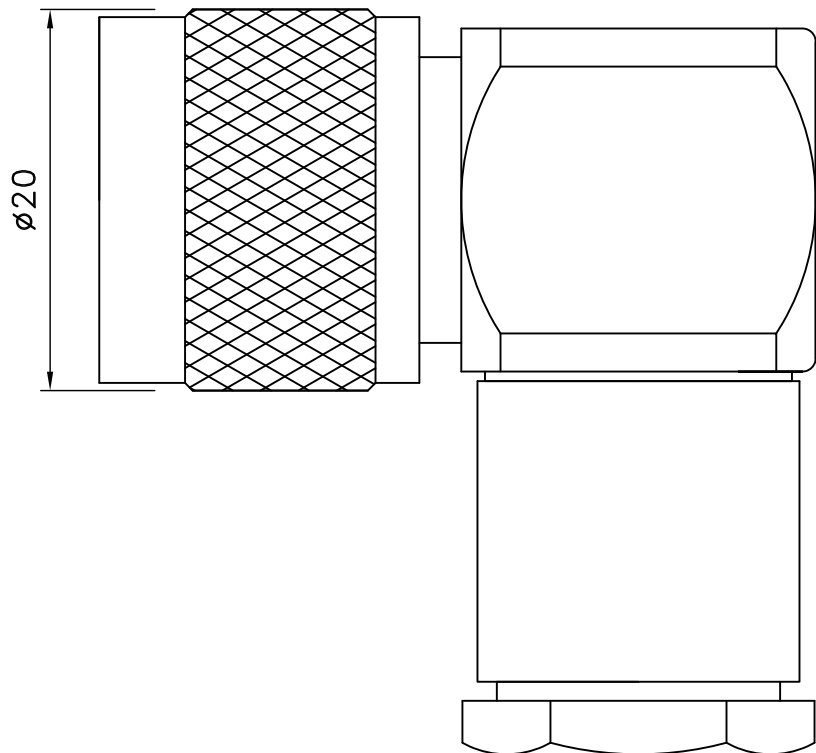

RG58



RG213



LMR600



1/2"

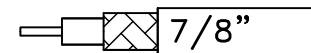

7/8"

NOTE:

CENTER PIN GOLD PLATING 3μ THICK OVER NICKEL PLATING
 70μ THICK OVER NICKEL STRIKE
 BODY NICKEL PLATING 70μ THICK OVER NICKEL STRIKE
 BRASS AND PTFE PER SGS
 FINISH PLATING THICKNESS IN MICRO-INCHES
 COPPER PARTS AUTOMATIC CNC MANUFACTURING

Prohibit re-circulating



華耀科技有限公司
 Hwa Yao Technologies co.,Ltd

TITLE
 N MALE RIGHT ANGLE CLAMP
 DRAWING NO.
 N-1104

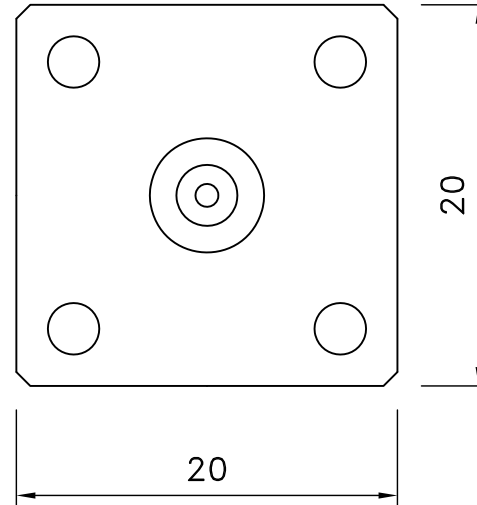
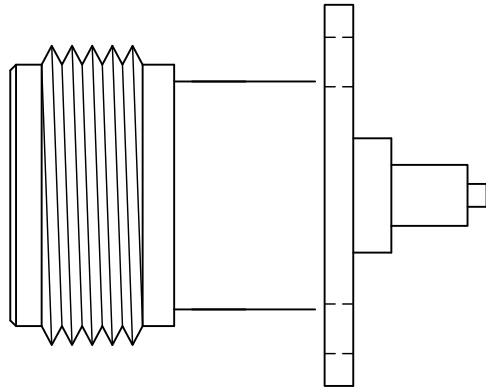

NOTE:

CENTER PIN GOLD PLATING 3μ THICK OVER NICKEL PLATING
 70μ THICK OVER NICKEL STRIKE
 BODY NICKEL PLATING 70μ THICK OVER NICKEL STRIKE
 BRASS AND PTFE PER SGS
 FINISH PLATING THICKNESS IN MICRO-INCHES
 COPPER PARTS AUTOMATIC CNC MANUFACTURING

Prohibit re-circulating



	華耀科技有限公司 <i>Hwa Yao Technologies co.,Ltd</i>
	TITLE N FEMALE PANEL MOUNT
	DRAWING NO. N-1127

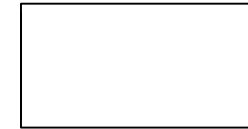
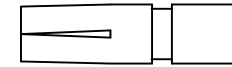
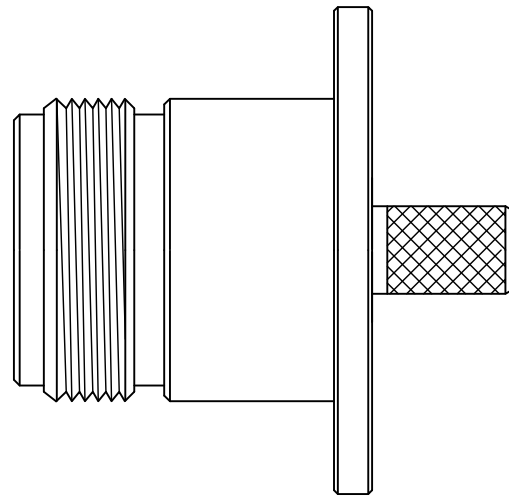
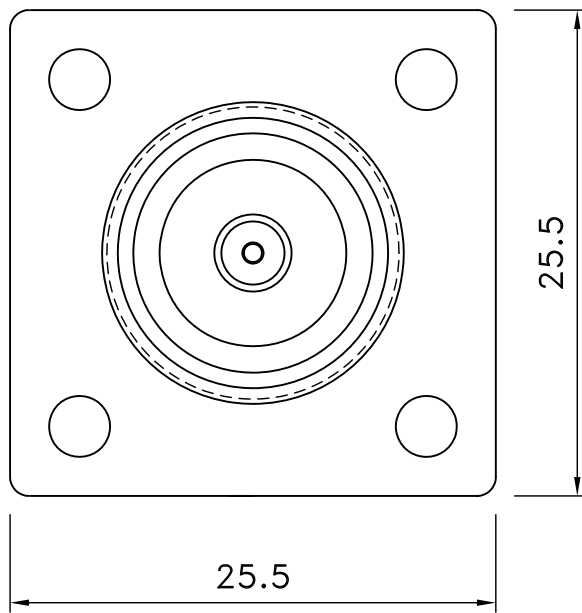

NOTE:

CENTER PIN GOLD PLATING 3μ THICK OVER NICKEL PLATING
 70μ THICK OVER NICKEL STRIKE
 BODY NICKEL PLATING 70μ THICK OVER NICKEL STRIKE
 BRASS AND PTFE PER SGS
 FINISH PLATING THICKNESS IN MICRO-INCHES
 COPPER PARTS AUTOMATIC CNC MANUFACTURING

Prohibit re-circulating



華耀科技有限公司
 Hwa Yao Technologies co.,Ltd

TITLE
 N FEMALE CRIMP PANEL MOUNT
 DRAWING NO.
 N-1113