

REV	DESCRIPTION	DRAWN	DATE

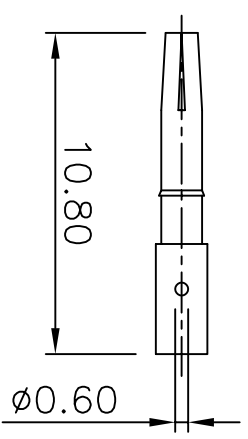
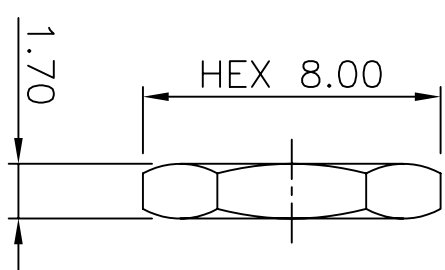
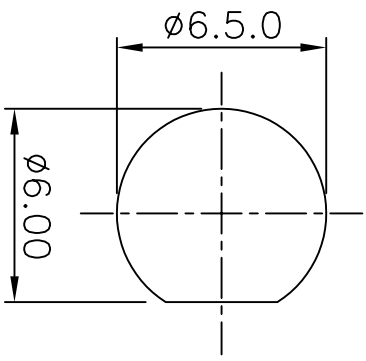
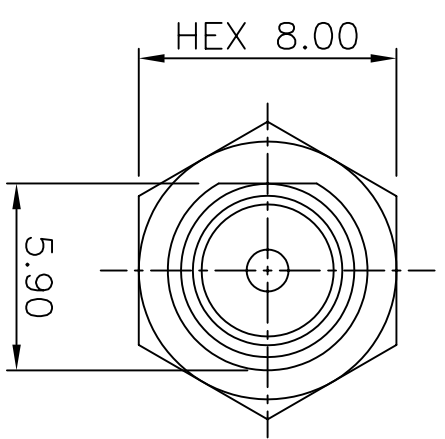
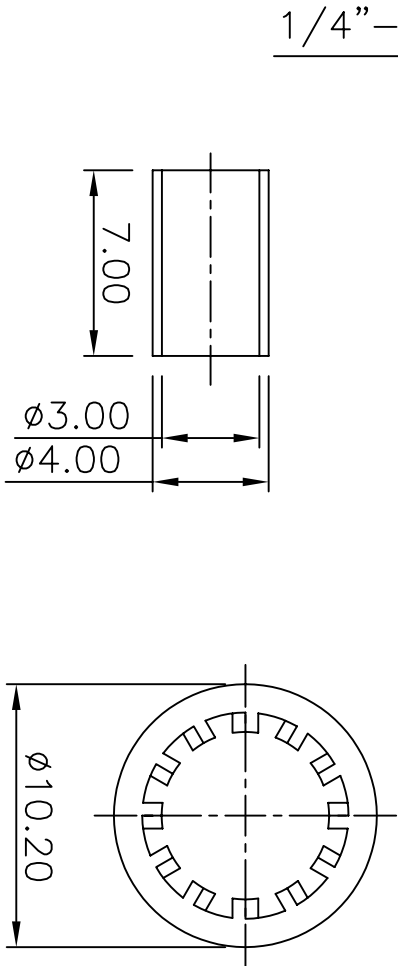
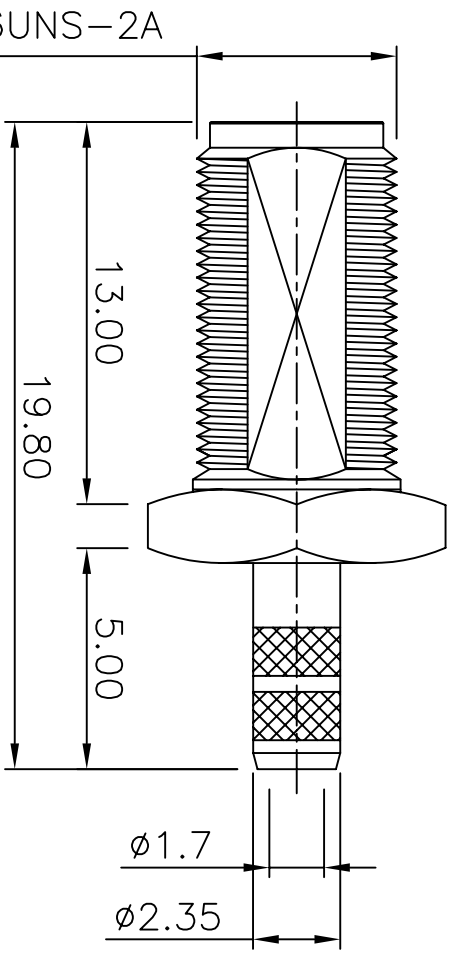

NO	Description	Qty	Material	Finish
6	NUT	1	BRASS	NICKEL
5	WASHER	1	BRASS	NICKEL
4	FERRULE	1	COPPER	NICKEL
3	DIELECTRIC	1	TEFLON	NONE
2	PIN	1	BERYLLIUM	GOLD
1	BODY	1	BRASS	NICKEL

UNLESS OTHERWISE SPECIFIED  
 1.REMOVE ALL BURRS  
 2.BREAK ALL CORNERS & EDGES CO.1.5 MAX.  
 3.CHAMFER 15° & LAST THREADS 45°.  
 4.DIAMETERS ON COMMON CENTERS  
 TO BE CONCENTRIC WITH DIMENSIONS  
 5. ALL DIMENSIONS ARE AFTER PLATING.

\* MAJOR DIMENSION  
 UNLESS OTHERWISE NOTED TOLERANCES  
 0.5-6 = ±0.2  
 6-30 = ±0.4  
 30-120 = ±0.6  
 120-315 = ±1.0  
 ANGLES = ±1°

APPROVED  
 CHECKED  
 DRAWN  
 Betty

華耀科技有限公司  
 Hua Yao Technologies co.,Ltd  
 TITLE  
 SMA FEMALE BULKHEAD CRIMP  
 DRAWING NO.  
 SMA-1012-50-L-TGN  
 FILE NO. D:\DWG\SMA FEMALE BULKHEAD CRIMP\SMA-1012-50-L-TGN  
 REV A  
 LY

SCALE	5/1	UNIT	MM	DRAWN DATE	06/11/30
-------	-----	------	----	------------	----------