

REV	DESCRIPTION	DRAWN	DATE

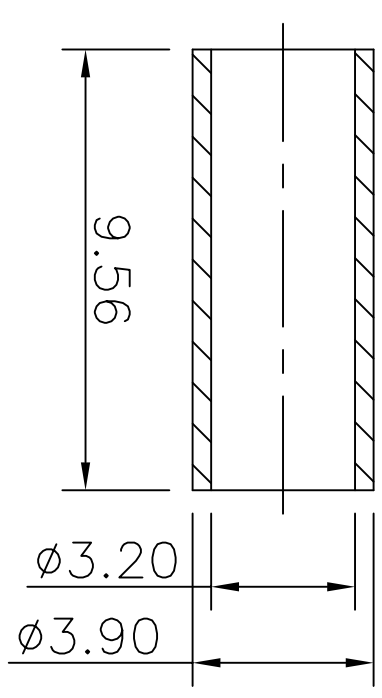
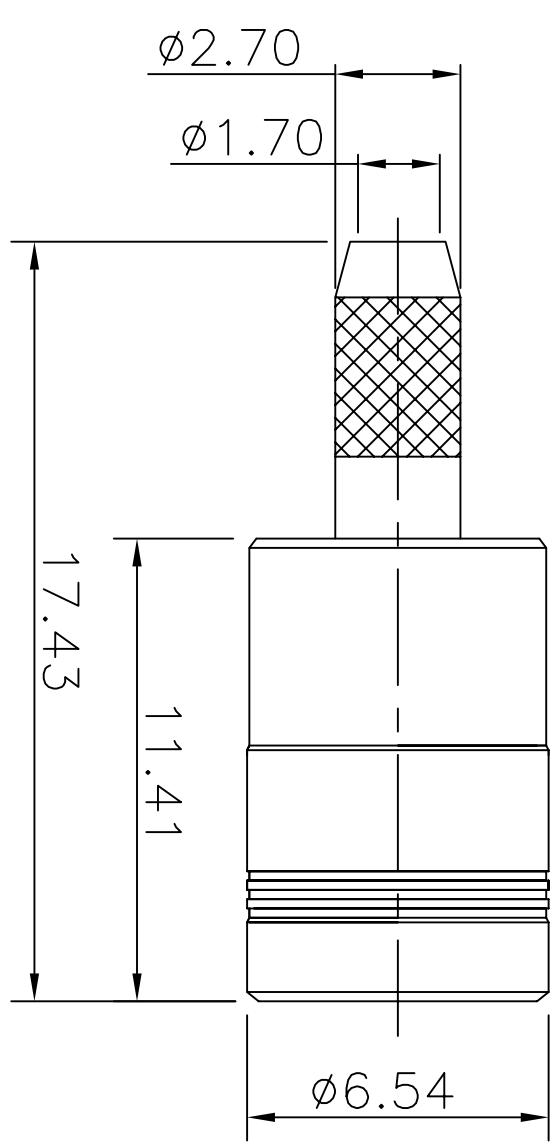
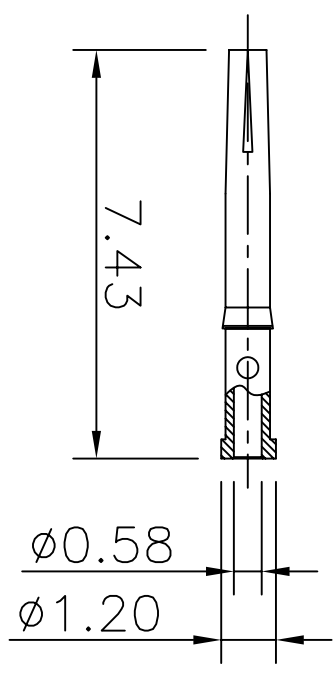

NO	Description	Qty	Material	Finish
7	RETAINING RING	1	BERYLLIUM	GOLD
6	FERRULE	1	COPPER	GOLD
5	FERRULE	1	BRASS	GOLD
4	DIELECTRIC	1	TEFLON	NONE
3	PIN	1	BERYLLIUM	GOLD
2	BODY	1	BRASS	GOLD
1	BODY	1	BRASS	GOLD

UNLESS OTHERWISE SPECIFIED  
 1.REMOVE ALL BURRS  
 2.BREAK ALL CORNERS & EDGES CO.15 MAX.  
 3.CHAMFER 15° & LAST THREADS 45°.  
 4.DIAMETERS ON COMMON CENTERS.  
 5.ALL DIMENSIONS ARE WITHIN TOLERANCES AFTER PLATING.

\* MAJOR DIMENSION UNLESS OTHERWISE NOTED. TOLERANCES  
 0.5-6=±0.2  
 6-30=±0.4  
 30-120=±0.6  
 120-315=±1.0  
 ANGLES=±1°

APPROVED  
 CHECKED  
 DRAWN Betty  
 SCALE 6/1 UNIT MM  
 DRAWN DATE 07/01/11

**華耀科技有限公司**  
 Hua Yao Technologies co.,Ltd  
 TITLE SMB MALE CRIMP  
 DRAWING NO. SMB-18111-5-L-TGG  
 FILE NO. D:\DWG\SMB MALE CRIMP\SMB-1811-5-L-TGG  
 REV A  
 GH