

REV	DESCRIPTION	DRAWN	DATE

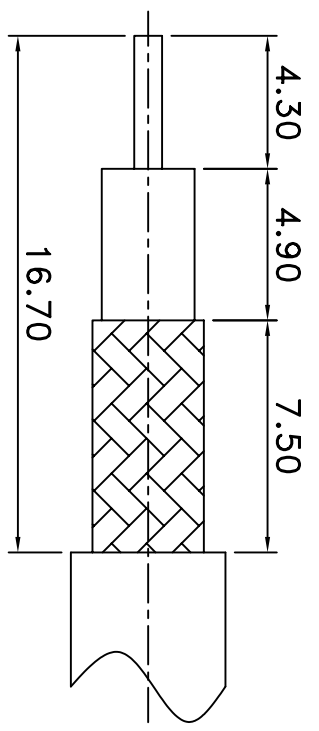
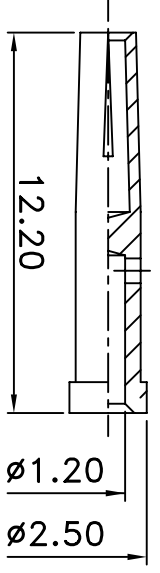
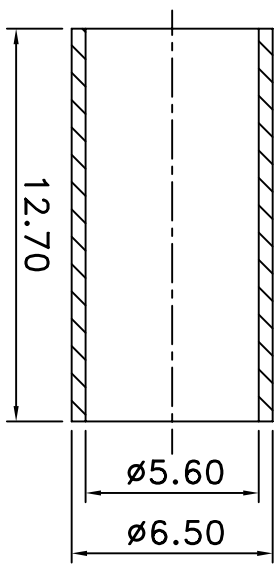
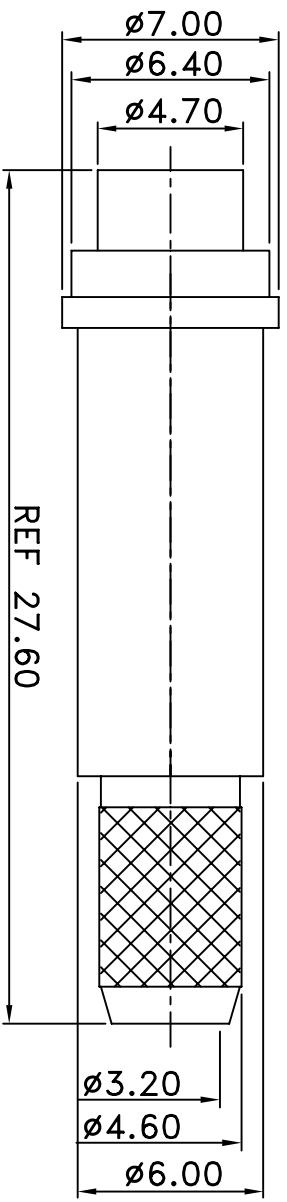
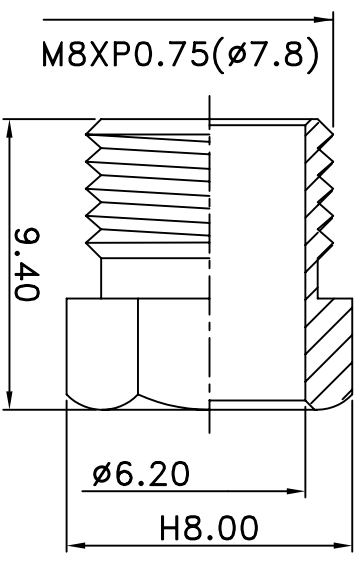

NO	Description	Qty	Material	Finish
5	DIELECTRIC	1	TEFLON	NONE
4	NUT	1	BRASS	NICKEL
3	FERRULE	1	BRASS	NICKEL
2	PIN	1	BRASS	GOLD
1	BODY	1	BRASS	NICKEL

UNLESS OTHERWISE SPECIFIED  
 1.REMOVE ALL BURRS  
 2.BREAK ALL CORNERS & EDGES CO.1.5 MAX.  
 3.CHAMFER 15° & LAST THREADS 45°  
 4.DIAMETERS ON COMMON CENTERS  
 TO BE CONCENTRIC WITH DIMENSIONS  
 5.ALL DIMENSIONS ARE AFTER PLATING.

\* MAJOR DIMENSION UNLESS OTHERWISE NOTED. TOLERANCES  
 0.5-6=±0.2  
 6-30=±0.4  
 30-120=±0.6  
 120-315=±1.0  
 ANGLES=±1°

APPROVED  
 Sandra  
 CHECKED  
 Betty  
 DRAWN  
 Betty

**華耀科技有限公司**  
 Hua Yao Technologies co.,Ltd  
 TITLE  
 FME FEMALE CRIMP  
 DRAWING NO.  
 FME-2016-1-F-DGN  
 FILE NO. D:\DWG\FME FEMALE CRIMP\FME-2016-1-F-DGN  
 REV  
 A